



A WORLD OF SLICERS & FOOD PREPARATION MACHINES



CATALOGO



INDICE - INDEX

Affettatrici / Slicers

- 7 LUNA *Light duty*
- 8 GALATEA *Light duty*
- 9 EUPHORIA *Light duty*
- 10 JOY *Light duty*
- 11 GAIA *Light - Medium duty*
- 12 ELEGANT *Medium duty*
- 14 PRIMA *Medium duty*
- 16 START *Heavy duty*
- 17 START SUPER *Heavy duty*
- 18 START AUTO *Heavy duty*
- 19 START SUPER AUTO *Heavy duty*
- 20 TITANIA *Heavy duty*
- 20 TITANIA LUX *Heavy duty*
- 21 ROYAL *Heavy duty*
- 21 ROYAL LUX *Heavy duty*
- 22 MAX G *Heavy duty*
- 23 MONDIAL *Heavy duty*
- 24 STRATOS 350 *Heavy duty*
- 26 ELEKTRA *Medium duty*
- 27 MAX SV - MAX CV *Heavy duty*
- 28 BETA CV *Heavy duty*
- 29 BETA SV *Heavy duty*

Preparazione / Food preparation

- 31 SV 2K *cottura sottovuoto / sous vide cooking system*
- 32 BREEZE M *sottovuoto / vacuum packaging*
- 33 BREEZE *sottovuoto / vacuum packaging*
- 34 GHIBLI *sottovuoto / vacuum packaging*
- 36 VEG 500 *tagliaverdure / vegetable cutters*
- 37 MARLIN *cutter / bowl cutter*
- 38 MISTRAL S *frullatori a immersione / hand-held mixer*
- 39 MISTRAL M *frullatori a immersione / hand-held mixer*
- 40 MISTRAL L *frullatori a immersione / hand-held mixer*
- 41 LYNX CG *grattugia / cheese grater*
- 41 PANTHER CG *grattugia / cheese grater*
- 42 LYNX 12 - PANTHER 22 *tritacarne / meat mincers*
- 43 LYNX 12 inox - PANTHER 22 inox *tritacarne / meat mincers*
- 44 TIGER *tritacarne / meat mincers*
- 45 SPEEDY L *hamburgatrice / hamburger presses*
- 46 BS *segaossa / bone saws*
- 47 BS inox *segaossa / bone saws*

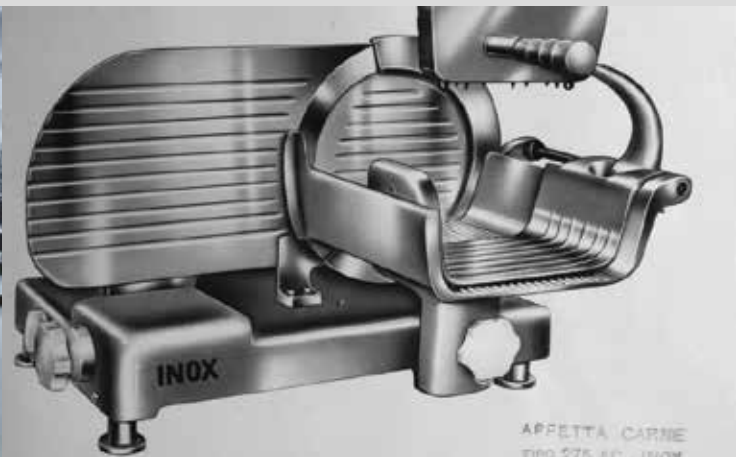

Italian Slicers riunisce Essedue e Rheninghaus, storiche aziende italiane conosciute internazionalmente per la produzione di affettatrici domestiche e professionali d'alta gamma.

Scegliere il nostro marchio significa entrare in una realtà fatta di passione, stile e qualità noto in tutto il mondo.

- ✓ **Stile professionale 100% italiano**
- ✓ **Alta qualità dei materiali**
- ✓ **Macchine facili da usare e da pulire**
- ✓ **Garanzia di totale sicurezza d'uso**
- ✓ **Supporto e assistenza in tutto il mondo**

1950

A Torino nascono le produzioni Rheninghaus e Oberwerk di affettatrici a volano.
The Rheninghaus and Oberwerk productions of flywheel slicers were born in Turin.



1970

Rheninghaus inizia la produzione delle affettatrici a uscita libera della fetta: Ministar, Mondial, Beta.
Rheninghaus begins the production of the clear slice exit slicers: Ministar, Mondial, Beta.



1990

Rheninghaus e Oberwerk si uniscono. Partecipazione alla elaborazione della norma europea EN1974.
Rheninghaus and Oberwerk merge. Participation in the elaboration of the European standard EN1974



2010

Viene ottenuta la certificazione NSF, la più esigente e restrittiva.
NSFB certification, the most demanding and restrictive, is obtained.

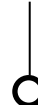

1950

Rheninghaus inizia la produzione di affettatrici in alluminio anodizzato, tritacarne e segaossi. Oberwerk si specializza nelle produzioni in acciaio inossidabile.
Rheninghaus production expanded with anodized aluminium slicers, meat mincers and bone saws. Oberwerk specializes in stainless steel productions.

1980

Ha inizio l'elaborazione di nuove soluzioni per garantire la sicurezza antinfortunistica e l'igiene.
The development of new solutions to ensure accident prevention and hygiene begins.

2000

Inizia la produzione di MONDIAL EVO. Il marchio Rheninghaus è distribuito in oltre cinquanta paesi.
MONDIAL EVO production begins. The Rheninghaus brand is distributed in over fifty countries.

1990

Vengono sviluppate nuove tecnologie.
Improvements are made to all production lines introducing new technologies.

2007

Inizia la produzione di nuove affettatrici con trasmissione ad ingranaggi.
The production of new gear-driven slicers begins.

2013

Prendono il via nuovi e importanti progetti in conto terzi.
New and important OEM (original equipment manufacturer) projects start.

1986

A Cura Carpignano nasce Essedue Sri.
Essedue Sri was Essedue, founded in Cura Carpignano.



2000

Essedue esporta i suoi prodotti in tutto il mondo.
The international market grows and Essedue brings its products all over the world.

2012

Nasce la ATC 350, prima affettatrice brevettata da Essedue.
The ATC 350 is born: the first s/cer patented by Essedue.

OUR COMPANY



Italian Slicers brings together Essedue and Rheninghaus, historic Italian companies known internationally for the production of high-end professional and household slicers.

Choosing our brand means entering a reality of passion, style and quality known all over the world.

- ✓ **100% Italian professional style**
- ✓ **High quality materials**
- ✓ **Easy to use and clean machines**
- ✓ **Guarantee of total safety of use**
- ✓ **Worldwide support and assistance**



2016
Essedue Sri
acquisisce
Rheninghaus.
*Esseoue Sri acquires
Rheninghaus..*

2018
Inizia la collaborazione
con Università dei
Sapori.
*Collaboration with
Università dei Sapori
starts.*

2019
L'azienda ottiene la
certificazione per tutte
le sue affettatrici per il
contatto con gli alimenti.
*The company obtains
the certification for all the
slicers for food contact
materials.*

2020
Nasce X35, affettatrice
con lama da 350mm
completamente in
acciaio inox.
*A 350mm blade slicer
X35 is born, completely
in stainless steel.*

2021
L'offerta si amplia
includendo nuove
attrezzature per la
ristorazione.
*The range of products
expands to include
additional equipment
for the HoReCa.*

2024
L'azienda viene rilevata da
M-Holding. Inizia così un nuovo
percorso ricco di investimenti che
danno nuovi impulsi e portano a
grandi innovazioni.
*The company is acquired by
M-Holding. Thus begins a new
path full of investments that give
new impulses and lead to great
innovations.*

AFFETTATRICI SLICERS

Vasta gamma di affettatrici, progettate per soddisfare le esigenze di ristoranti, gastronomie e professionisti della cucina. Le nostre affettatrici combinano precisione, efficienza e sicurezza, garantendo fette perfette di salumi, formaggi e altri alimenti. Realizzate con materiali di alta qualità e tecnologie all'avanguardia, sono adatte a ogni tipo di utilizzo, dal professionale al domestico. Scoprite come le nostre affettatrici possono migliorare la vostra esperienza culinaria, rendendo ogni piatto un'opera d'arte!

*Wide range of slicers, designed to meet the needs of restaurants, delicatessens and kitchen professionals.
Our slicers combine precision, efficiency and safety, ensuring perfect slices of cured meats, cheeses and other foods.
Made with high-quality materials and cutting-edge technologies, they are suitable for all types of use, from professional to domestic.
Discover how our slicers can improve your culinary experience, making each dish a work of art!*

VERSIONI AFFETTATRICI SLICERS VERSION

Extra EU



- 1 Parapollice
Small hand guard
- 2 Interruttore basculante
Rocker switch

CE Domestico *CE Domestic use*



- 1 Parapollice
Small hand guard
- 2 Interruttore basculante
Rocker switch
- 3 Microinterruttore su paralama
Microswitch on blade cover
- 4 Protezione inferiore
Bottom shield

CE Professionale *CE Professional*

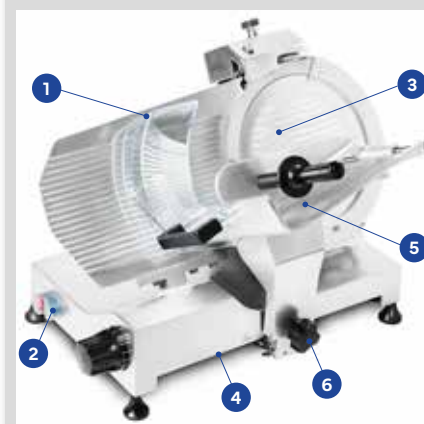

- 1 Paramano grande
Large hand guard
- 2 Comandi con NVR
NVR controls
- 3 Microinterruttore su paralama
Microswitch on blade cover
- 4 Protezione inferiore
Bottom shield
- 5 Manopola pressamerce lunga
Long product pusher handle
- 6 Meccanismo sgancio piatto affettatrice
Carriage interlock on open gauge
- 7 Anello protezione lama in acciaio inox
Stainless steel blade protection ring



OPZIONI DISPONIBILI AVAILABLE OPTIONALS



Lama dentata
Serrated blade



Lama antiaderente
Non stick coated blade



Estrattore lama
Blade removal tool
(Only CE Prof)



Estrattore lama SBR
SBR Blade removal tool
(Only CE Prof)



Quantium

LUNA 195	✓	✓			
GALATEA 220	✓	✓			
GALATEA 250	✓	✓			
EUPHORIA 220	✓	✓	✓		
EUPHORIA 250	✓	✓	✓		
JOY 250	✓	✓	✓		
JOY 275	✓	✓	✓		
JOY 300	✓	✓	✓		
GAIA S 250	✓	✓	✓		
GAIA M 300	✓	✓	✓		
ELEGANT 300	✓	✓	✓		✓
PRIMA 250	✓	✓	✓	✓	✓
PRIMA 300	✓	✓	✓	✓	✓
START 300	✓	✓	✓	✓	✓
START 350	✓	✓	✓	✓	✓
START SUPER 300	✓	✓	✓	✓	✓
START SUPER 350	✓	✓	✓	✓	✓
START AUTO 300	✓	✓	✓	✓	✓
START AUTO 350	✓	✓	✓	✓	✓
START SUPER AUTO 300	✓	✓	✓	✓	✓
START SUPER AUTO 350	✓	✓	✓	✓	✓
TITANIA 300	✓	✓	✓		
TITANIA 330	✓	✓	✓		
TITANIA LUX 300	✓	✓	✓		✓
ROYAL 350	✓	✓	✓		
ROYAL LUX 350	✓	✓	✓		✓
MAX G 300	✓	✓	✓		✓
MAX G 350	✓	✓	✓		✓
MAX G 370	✓	✓	✓		✓
MONDIAL 300	✓	✓	✓	✓	✓
MONDIAL 350	✓	✓	✓	✓	✓
X 35	✓	✓		✓	
ELEKTRA 300		✓	✓		
MAX SV 350			✓		
MAX SV 370			✓		
MAX CV 350		✓	✓		
MAX CV 370		✓	✓		
BETA CV 300		✓	✓	✓	✓
BETA CV 350		✓	✓	✓	✓
BETA SV 300		✓	✓	✓	✓
BETA SV 350		✓	✓	✓	✓



LUNA 195

La piccola della famiglia! Affettatrice in alluminio anodizzato con affilatoio separato (da montare solo durante l'affilatura) e lama in acciaio dal diametro di 195mm. La sua forma ad "L" unica e inconfondibile permette di servire il prodotto tagliato direttamente nel piatto di portata. Grazie alle sue dimensioni ridotte trova spazio in tutte le cucine: perfetta per chi non vuole rinunciare ad un affettato sempre fresco e sottile.

The smallest slicer in the family! Slicer in anodized aluminum casting construction with separate blade sharpener (to be mounted only during sharpening). C45 steel blade. The unique "L" shape of the slicer base allows you to serve the cut product directly in the serving dish. Thanks to its small size this slicer fits even in the smallest kitchens and is perfect for those who do not want to renounce an always fresh and thin slicing.









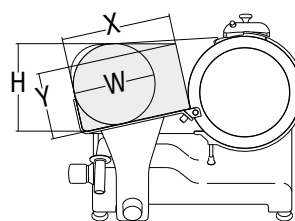
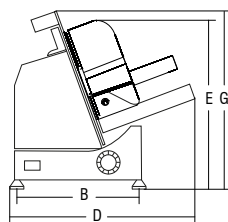
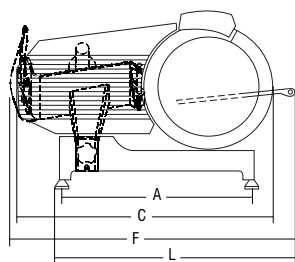

Affilatoio scorporato
Separate sharpener



Versione Extra EU
Extra EU Version



						A	B	C	D	E	F	G	L	X	Y	H	W			
	mm-inch	watt-Hp	mm	mm	mm	mm	mm	mm	mm	mm	mm	mm	mm	mm	mm	mm	mm	kg	mm	kg
LUNA 195	195/8"	110/0,15	15	200	155x190	350	220	430	300	310	570	335	400	175	130	130	130	8,8	450x330x330	9,8

GALATEA 220 - 250

Affettatrice in alluminio pressofuso con lama in acciaio dal diametro di 220 e 250 mm.

Galatea 220 con affilatoio separato

Sceglila se vuoi un'affettatrice compatta ma robusta che trova spazio in ogni cucina. Perfetta per affettare salumi di piccole dimensioni.

Die-cast aluminum slicer with steel blade with a diameter of 220 and 250 mm.

Galatea 220 with separate sharpener

Choose it if you want a compact but sturdy slicer that finds space in any kitchen. Perfect for slicing small cured meats.

OPZIONI

- + colore rosso
- + base brillantata

OPTIONALS

- + red color
- + stone polished body



GALATEA 220









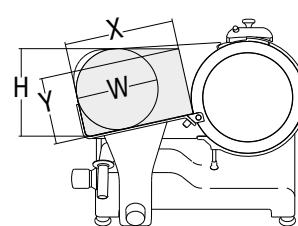
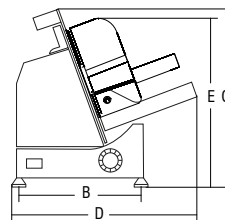
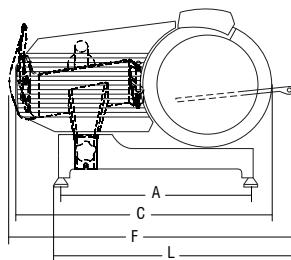

GALATEA 250



Affilatoio scorporato
Separate sharpener



						A	B	C	D	E	F	G	L	X	Y	H	W			
	mm-inch	watt-Hp	mm	mm	mm	mm	mm	mm	mm	mm	mm	mm	mm	mm	mm	mm	mm	kg	mm	kg
GALATEA 220	220/9"	130/0,17	15	210	200x190	380	260	460	410	340	595	390	430	175	120	140	130	12	540x460x410	14,3
GALATEA 250	250/10"	130/0,17	15	210	200x200	380	260	510	420	380	610	390	530	180	150	175	175	12	540x460x410	14,3

EUPHORIA 220 - 250

Affettatrici in alluminio anodizzato con affilatoio fisso e lama in acciaio disponibile con diametro di 220mm, e 250mm. Si tratta di affettatrici molto versatili, adatte per il taglio di salumi e verdure. Queste affettatrici si distinguono per l'alta qualità dei materiali con i quali sono composte. Disponibili in varie misure, si adattano ad ogni cucina!

Anodized aluminum slicers with fixed sharpener and steel blade available in 220mm, and 250mm diameter. This is a very versatile slicers, suitable for cutting cured meats and vegetables. This slicer, adapting to any kitchen, is distinguished by the high quality of the materials with which they are made.



EUPHORIA 220 CE PROF









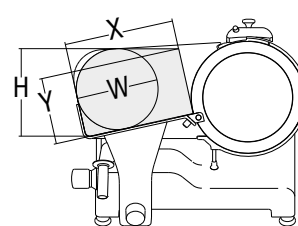
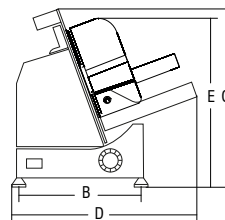
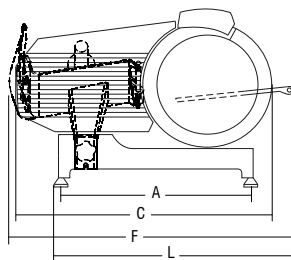

EUPHORIA 250 CE PROF



Versione CE domestico
CE domestic Version



						A	B	C	D	E	F	G	L	X	Y	H	W			
	mm-inch	watt-Hp	mm	mm	mm	mm	mm	mm	mm	mm	mm	mm	mm	mm	mm	mm	mm	kg	mm	kg
EUPHORIA 220	220/9"	150/0,20	14	205	200x200	360	260	480	420	355	610	370	530	180	145	165	160	12,5	540x460x430	14,75
EUPHORIA 250	250/10"	150/0,20	14	205	200x200	360	260	500	420	355	610	370	530	175	155	175	175	13	540x460x430	15,25

JOY 250 - 275 - 300

Affettatrici in alluminio anodizzato con affilatoio fisso. Lama in acciaio C45. Anello di protezione in acciaio inossidabile. Robuste e durevoli, facili da utilizzare e pulire. Perfette per il taglio di salumi, carne, verdure. Ideale per ristoranti, gastronomie, bar.

Anodized aluminum slicers casting construction with fixed sharpener. C45 steel blade. CE version with stainless steel protection ring. Robust and durable, easy to use and clean. Perfect for cutting cold cuts, meat, vegetables. Ideal for restaurants, small supermarkets, deli-shops, bars.



JOY 250 PROF







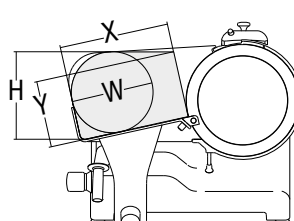
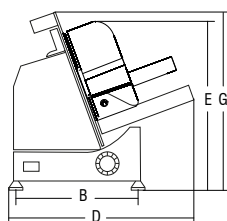
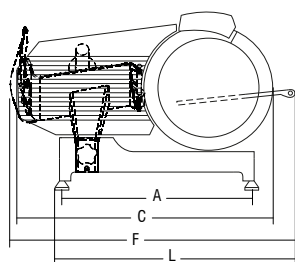

JOY 275 PROF

JOY 300 PROF



Versione CE domestico
CE domestic Version



						A	B	C	D	E	F	G	L	X	Y	H	W			
	mm-inch	watt-Hp	mm	mm	mm	mm	mm	mm	mm	mm	mm	mm	mm	mm	mm	mm	mm	kg	mm	kg
JOY 250	250/10"	210/0,28	15	262	230x220	430	275	570	440	415	650	415	550	230	163	190	185	16	630x560x460	19,5
JOY 275	275/11"	210/0,28	15	262	230x220	430	275	590	445	415	650	415	550	225	175	200	195	16,5	630x560x460	20,0
JOY 300	300/12"	210/0,28	15	253	230x220	430	275	590	443	415	650	415	550	215	190	215	210	17,5	630x560x460	21,0

GAIA

S 250 - M 300

Affettatrici caratterizzate da linee morbide. La base tondeggiante conferisce uno stile armonioso a tutta la macchina. Struttura in alluminio anodizzato. Anello di protezione in acciaio inossidabile. Lama in acciaio C45, disponibile nei diametri 250mm e 300mm. Facili da usare e da pulire grazie alle linee tonde. Perfette per il taglio di salumi, carne, verdure, formaggi. Ideali per ristoranti e bar.

The slicers have smooth lines. The rounded base gives a harmonious style to the whole machine. Anodized aluminum casting construction. CE version with stainless steel protection ring around the blade and alloy sharpener. The other version has a sharpener cover in black plastic. C45 steel blade, available in 250mm and 300mm diameters. Easy to use and clean thanks to the round lines. Perfect for slicing cold cuts, meat, vegetables, cheese. Ideal for restaurants and bars.



GAIA S 250 CE PROF



GAIA M 300 CE PROF











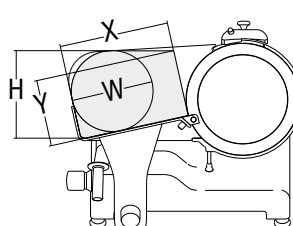
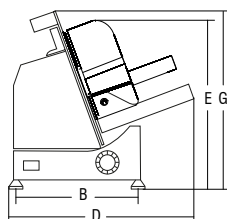
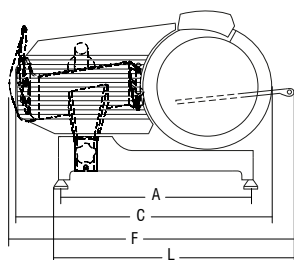









Versione CE domestico
CE domestic Version

OPZIONI/OPTIONALS



Piatto per taglio inclinato
Inclinated product holder



																				
	mm-inch	watt-Hp	mm	mm	mm	mm	mm	mm	mm	mm	mm	mm	mm	mm	mm	mm	kg	mm	kg	
GAIA S 250	250/10"	170/0,23	16	200	200x200	370	280	460	400	435	595	435	550	165	165	180	180	15	545x485x445	18.0
GAIA M 300	300/12"	210/0,28	15	235	260x235	435	300	585	510	440	660	460	570	227	200	220	220	21	700x580x470	26



ELEGANT 300

Affettatrice con struttura in alluminio anodizzato e lama in acciaio C45 dal diametro di 300mm, con anello di protezione in alluminio. Grazie alla sua base compatta è un'affettatrice che risulta leggera e maneggevole. Perfetta per il taglio di salumi, carne, verdure. Ideale per ristoranti, hotel, catering, gastronomie, bar.

Slicer with anodized aluminum casting construction and C45 steel blade with a diameter of 300mm. CE Version with aluminum protection ring around the blade. Thanks to its compact size, it is a slicer light and easy to handle. Perfect for slicing cold cuts, meat, vegetables. Ideal for restaurants, hotels, catering, delicatessens, bars.



OPZIONI / OPTIONALS

+ Quantanium



Versione CE domestico
CE domestic Version

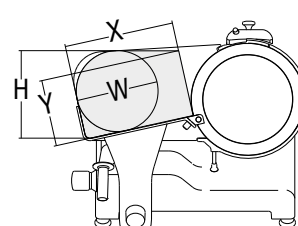
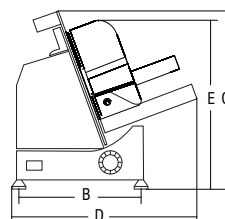
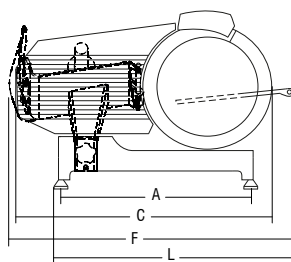

	mm-inch	watt-Hp	mm	mm	mm	mm	mm	mm	mm	mm	mm	mm	mm	mm	mm	mm	kg	mm	kg	
ELEGANT 300	300/12"	210/0,28	14	275	260x235	455	300	590	480	445	610	510	630	240	180	205	205	21	630x560x460	24,5



MEDIUM DUTY



PRIMA 250 - 300

PRIMA è una moderna affettatrice con un design unico ed ergonomico: macchina multiuso, ideale nella preparazione di sandwich e per affettare diversi prodotti. Colori vivaci e un bel design che trova il giusto spazio in bar e piccoli ristoranti attenti agli elementi di arredo. Due dimensioni disponibili: con lama da 250mm e 300mm.

USCITA LIBERA DELLA FETTA: l'intera area dietro la lama è completamente libera.

PRIMA is a modern slicer with an unique and ergonomic design: multipurpose machine, ideal in the sandwich preparation and to slice different products. Fresh colours and nice design for easy installation in trendy bars and small restaurants.

Two available sizes: with 250mm or 300mm blade.

CLEAR SLICE EXIT DESIGN: the entire area behind the blade is completely free



- ✓ Ampia area di raccolta
- ✓ Regolazione precisa dello spessore delle fette: meccanismo sigillato a tenuta
- ✓ Scorrimento dolce del carrello
- ✓ Piatto rimovibile con dispositivo di blocco

- ✓ Wide slice collection area
- ✓ Thickness adjustment gasket-sealed mechanism
- ✓ Carriage smooth glide motion
- ✓ Removable product holder with interlock device

OPZIONI/OPTIONALS

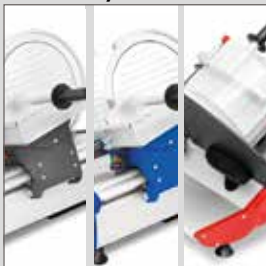

Altri colori disponibili
Other available colors



Piedini speciali per forniture navali
Special feet for calley fitting



Piatto per taglio inclinato
Inclined product holder









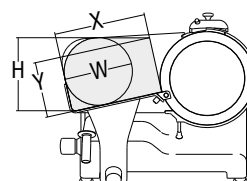
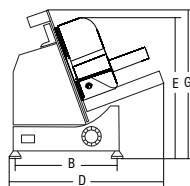
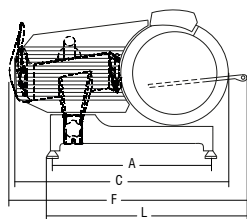













Quantanium



Estrattore lama SBR
SBR blade removal tool



																				
	mm-inch	watt-Hp	mm	mm	mm	mm	mm	mm	mm	mm	mm	mm	mm	mm	mm	mm	mm	kg	mm	kg
PRIMA 250	250/10"	185/0,25	15	260	230x240	460	310	545	430	370	540	370	535	160	60	180	330	23	620x550x450	25
PRIMA 300	300/12"	220/0,30	15	280	255x280	480	310	630	430	415	625	415	620	190	60	220	360	25	740x600x560	29

PRIMA PESCE L'inclinazione regolabile del piatto garantisce grandi fette da filetti stretti



PRIMA FISH The adjustable inclined product-holder guarantees large slices from narrow fillets



- ✔ Speciale piatto in acciaio inox
Special stainless steel product holder

PRIMA PANE E' in grado di tagliare qualsiasi tipo di pane senza romperne la crosta. Il design con uscita libera della fetta è adatto per il taglio del pane



PRIMA BREAD It can cut any type of bread without breaking the crust. Clear slice exit design is suited for bread cutting



- ✔ Lama seghettata
Serrated blade
- ✔ Rivestimento antiaderente
Non-stick coating
- ✔ Piatto speciale
Special product holder

PRIMA FORMAGGIO Vela e coprilama in Quantanium



PRIMA CHEESE Quantanium thickness gauge plate and blade cover



HEAVY DUTY



START 300 - 350

START è un'affettatrice potente con un ottimo rapporto qualità/prezzo. Questa macchina robusta e maneggevole è la miglior soluzione quando sicurezza ed igiene sono le priorità. Le protezioni speciali la rendono adatta agli ambienti umidi. Ideale per alimentari, supermercati, ristoranti, hotel, aziende di catering. Due misure disponibili: con lama da 300mm o 350mm

START is a powerful slicer with great quality/price ratio. This handy and sturdy machine is the best solution when safety and hygiene are main priorities. The special protections make it suited for humid environments. Ideal for deli-shops, supermarkets, restaurants, hotels, catering companies. Two available sizes: with 300mm or 350mm blade.



START 300



START 350

- ✓ Scorrimento dolce del carrello
- ✓ Costruzione robusta per tagli precisi
- ✓ Regolazione dello spessore: guarnizione sigillata
- ✓ Ampio spazio tra lama e base. Elevata protezione contro l'umidità
- ✓ Motore potente e silenzioso
- ✓ Ampia area di raccolta fette con bordo anti-goccia
- ✓ Mod. 300 con piatto in alluminio anodizzato, Mod.350 con piatto in acciaio inox

- ✓ Carriage smooth glide motion
- ✓ Sturdy construction for precise slices
- ✓ Thickness adjustment: gasket-sealed mechanism
- ✓ Large clearance between blade and base. High protection against moisture
- ✓ Powerful and noiseless motor
- ✓ Wide slice exit area with no-drip profile
- ✓ Mod. 300 with anodized aluminum plate, Mod. 350 with stainless steel plate

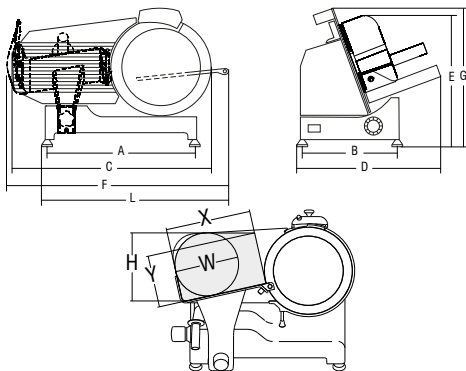

OPZIONI/OPTIONALS



Piatto per taglio inclinato
Inclined product holder



Quantanium



Estrattore lama SBR
SBR blade removal tool

	mm-inch	watt-Hp	mm	mm	mm	mm	mm	mm	mm	mm	mm	mm	mm	mm	mm	mm	mm	kg	mm	kg
START 300	300/12"	270/0,37	20	330	250x255	565	380	620	560	470	650	470	640	200	100	230	330	29	740x580x560	35
START 350	350/14"	270/0,37	20	330	280x300	565	380	680	600	470	710	470	700	240	160	270	400	32	790x640x580	39

HEAVY DUTY



START SUPER 300 - 350

START SUPER è una potente affettatrice con trasmissione ad ingranaggi e con un ottimo rapporto qualità/prezzo. Questa macchina robusta e maneggevole è la miglior soluzione quando sicurezza ed igiene sono le priorità. Le protezioni speciali la rendono adatta agli ambienti umidi. Adatta al taglio di prodotti congelati con l'utilizzo della lama dentata. Ideale per alimentari, supermercati, ristoranti, hotel, aziende di catering. Due misure disponibili: con lama da 300mm o 350mm.

START SUPER is a powerful gear driven slicer with great quality/price ratio. This handy and sturdy machine is the best solution when safety and hygiene are main priorities. The special protections make it suited for humid environments. Ideal for deli-shops, supermarkets, restaurants, hotels, catering companies. Gear drive guarantees maximum power when cheese, frozen or hard products are sliced. Two available sizes: with 300mm or 350mm blade



START SUPER 300



START SUPER 350

- ✓ Scorrimento dolce del carrello
- ✓ Costruzione robusta per tagli precisi
- ✓ Regolazione dello spessore: guarnizione sigillata
- ✓ Ampio spazio tra lama e base. Elevata protezione contro l'umidità
- ✓ Motore potente e nessuna manutenzione alla trasmissione ad ingranaggi
- ✓ Ampia area di raccolta fette con bordo anti-goccia
- ✓ Mod. 300 con piatto in alluminio anodizzato, Mod.350 con piatto in acciaio inox

- ✓ Carriage smooth glide motion
- ✓ Sturdy construction for precise slices
- ✓ Thickness adjustment: gasket-sealed mechanism
- ✓ Large clearance between blade and base. High protection against moisture
- ✓ Powerful motor with maintenance-free gear drive
- ✓ Wide slice exit area with no-drip profile
- ✓ Mod. 300 with anodized aluminum plate, Mod. 350 with stainless steel plate

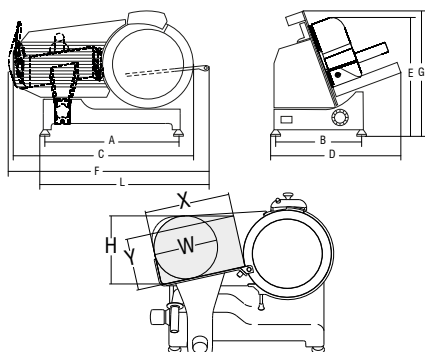

OPZIONI/OPTIONALS



















Piatto per taglio inclinato
Inclined product holder



Quantanium



Estrattore lama SBR
SBR blade removal tool

																				
	mm-inch	watt-Hp	mm	mm	mm	mm	mm	mm	mm	mm	mm	mm	mm	mm	mm	mm	kg			
START SUPER 300	300/12"	270/0,37	20	330	280x300	565	380	620	560	470	650	470	640	210	160	230	400	29	740x640x580	35
START SUPER 350	350/14"	270/0,37	20	330	280x300	565	380	680	600	470	710	470	700	240	160	270	400	32	790x640x580	39

HEAVY DUTY



START AUTO 300 - 350

START AUTO è una potente affettatrice automatica che può anche essere utilizzata manualmente. Robusta e performante: velocità del carrello selezionabile, per tagliare da 0 a 60 fette/min. Facile da usare e da pulire. Ideale per supermercati, ristoranti, aziende di catering, laboratori. Due misure disponibili: con lama da 300mm o 350mm. Alluminio anodizzato: robusto e leggero. Lama in lega di acciaio al cromo temprato di alta qualità. Motore ad uso continuo potente e silenzioso. Trasmissione a cinghia multigrigip: sempre la giusta trazione.

START AUTO is a powerful automatic slicer that can also be used manually. Sturdy and high performing: carriage speed selection from 0 up to 60 slices/min. Ideal for supermarkets, restaurants, catering companies, laboratories. Two available sizes: with 300 mm or 350 mm blade. Anodized aluminium casting construction: sturdy and light weight. High quality hardened chromium steel alloy blade. Powerful and noiseless continuous use motor. Special product holder with adjustable fence and three-position heavy food pusher. Programmable slices counter available.



- ✔ Spondina regolabile e pressamerce a tre posizioni
- ✔ Costruzione robusta per tagli precisi
- ✔ Regolazione dello spessore: guarnizione sigillata
- ✔ Ampio spazio tra lama e base. Elevata protezione contro l'umidità
- ✔ Motore potente e nessuna manutenzione alla trasmissione ad ingranaggi
- ✔ Ampia area di raccolta fette con bordo anti-goccia

- ✔ Adjustable fence and three-position heavy food pusher
- ✔ Sturdy construction for precise slices
- ✔ Thickness adjustment: gasket-sealed mechanism
- ✔ Large clearance between blade and base. High protection against moisture
- ✔ Powerful motor with maintenance-free gear drive
- ✔ Wide slice exit area with no-drip profile

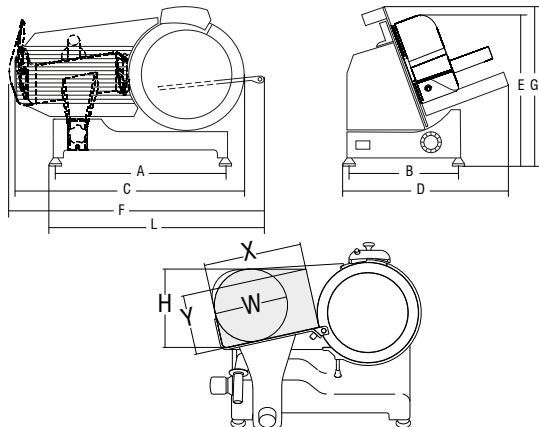

OPZIONI/OPTIONALS





















Contafette programmabile
Programmable slice counter



Quantanium



Estrattore lama SBR
SBR blade removal tool

																				
	mm-inch	watt-Hp	mm	mm	mm	mm	mm	mm	mm	mm	mm	mm	mm	mm	mm	mm	kg	mm	kg	
START AUTO 300	300/12"	270/0,37	20	330	300x300	575	390	620	725	595	660	595	640	190	130	220	415	43	830x730x710	50
START AUTO 350	350/14"	270/0,37	20	330	300x300	575	390	680	725	595	720	595	700	200	130	230	415	45	830x730x710	52



START SUPER AUTO

300 - 350

START SUPER AUTO è una potente affettatrice automatica che può essere utilizzata anche manualmente. Robusta e dalle alte prestazioni: velocità del carrello da 0 a 60 fette/minuto. Ideale per supermercati, ristoranti, aziende di catering, laboratori. La trasmissione ad ingranaggi garantisce la massima potenza quando è necessario tagliare formaggio e prodotti duri o congelati. Disponibile anche con dispositivo di programmazione e conteggio del numero delle fette. Due misure disponibili: con lama da 300mm o 350mm.

START SUPER AUTO is a powerful automatic slicer that can also be used manually. Sturdy and high performing: carriage speed selection from 0 up to 60 slices/min. Ideal for supermarkets, restaurants, catering companies, laboratories. Gear drive guarantees maximum power when cheese, frozen or hard products are sliced. Serrated blade available for frozen food and programmable slices counter. Two available sizes: with 300mm or 350mm blade.



- ✔ Spondina regolabile e pressamerce a tre posizioni
- ✔ Costruzione robusta per tagli precisi
- ✔ Regolazione dello spessore: guarnizione sigillata
- ✔ Ampio spazio tra lama e base. Elevata protezione contro l'umidità
- ✔ Motore potente e nessuna manutenzione alla trasmissione ad ingranaggi
- ✔ Ampia area di raccolta fette con bordo anti-goccia

- ✔ Adjustable fence and three-position heavy food pusher
- ✔ Sturdy construction for precise slices
- ✔ Thickness adjustment: gasket-sealed mechanism
- ✔ Large clearance between blade and base. High protection against moisture
- ✔ Powerful motor with maintenance-free gear drive
- ✔ Wide slice exit area with no-drip profile

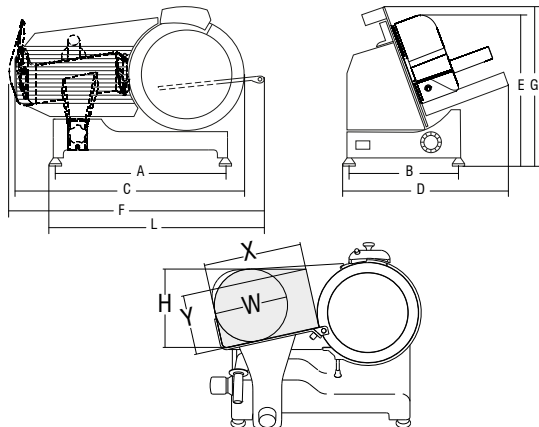

OPZIONI/OPTIONALS





















Contafette programmabile
Programmable slice counter



Quantanium



Estrattore lama SBR
SBR blade removal tool

																				
	mm-inch	watt-Hp	mm	mm	mm	mm	mm	mm	mm	mm	mm	mm	mm	mm	mm	mm	kg	mm	kg	
START SUPER AUTO 300	300/12"	270/0,37	20	330	300x300	575	390	620	725	595	660	595	640	190	130	220	415	43	830x730x710	50
START SUPER AUTO 350	350/14"	270/0,37	20	330	300x300	575	390	680	725	595	720	595	700	200	130	230	415	45	830x730x710	52

HEAVY DUTY



TITANIA - LUX 300 - 330

Affettatrici in alluminio anodizzato con affilatoio fisso.
Lama in acciaio C45.
Anello di protezione in alluminio.
Robuste e durevoli, facili da utilizzare e pulire.
Perfetta per il taglio di salumi, carne, verdura, formaggio.
Ideale per ristoranti, gastronomie e supermercati.

LUX 300

Maggiore spazio dietro alla lama per facilitare le operazioni di pulizia.
Anello di protezione in acciaio inossidabile.
Affilatoio avvolgente e protettivo.
Sigillo anti-infiltrazioni.
Ideali per ristoranti, hotel, catering, supermercati.

Slicers made in anodized aluminum casting construction with fixed sharpener. C45 steel blade. CE version with aluminum protection ring around the blade. Robust and durable, easy to use and clean. Perfect for cutting cold cuts, meat, vegetables and cheese. Ideal for restaurants, small supermarkets, delishops







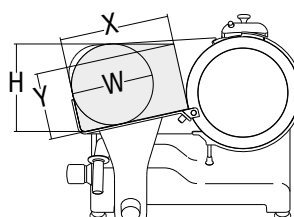
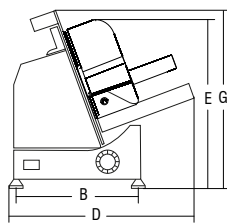
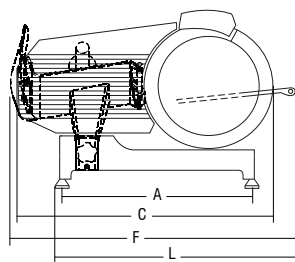

LUX 300

Slicers with larger clearance behind the blade to facilitate cleaning. Stainless steel protection ring around the blade. Enveloping and protective built-in sharpener. Anti-infiltration seal. Ideal for restaurants, hotels, catering, supermarkets.



OPZIONI/OPTIONALS



						A	B	C	D	E	F	G	L	X	Y	H	W			
	mm-inch	watt-Hp	mm	mm	mm	mm	mm	mm	mm	mm	mm	mm	mm	mm	mm	mm	mm	kg	mm	kg
TITANIA 300	300/12"	240/0,32	14	315	280x255	510	320	650	535	440	735	615	680	260	155	210	200	27	720x620x535	32
TITANIA 330	330/13"	270/0,36	14	315	280x255	510	320	675	535	460	735	615	680	260	165	220	215	28	760x650x570	35
TITANIA LUX 300	300/12"	240/0,32	14	315	280x255	510	320	650	535	470	735	615	680	255	155	210	200	28	720x620x535	35

HEAVY DUTY



ROYAL - LUX 350

Affettatrici in alluminio anodizzato con affilatoio fisso.
Lama in acciaio C45.
Anello di protezione in alluminio.
Robuste e durevoli, facili da utilizzare e pulire.
Perfetta per il taglio di salumi, carne, verdura, formaggio.
Ideale per ristoranti, gastronomie e supermercati.

LUX 350

Maggiore spazio dietro alla lama per facilitare le operazioni di pulizia.
Anello di protezione in acciaio inossidabile.
Affilatoio avvolgente e protettivo.
Sigillo anti-infiltrazioni.
Ideali per ristoranti, hotel, catering, supermercati.

Slicers made in anodized aluminum casting construction with fixed sharpener. C45 steel blade. CE version with aluminum protection ring around the blade. Robust and durable, easy to use and clean. Perfect for cutting cold cuts, meat, vegetables and cheese. Ideal for restaurants, small supermarkets, delishops

LUX 350

Slicers with larger clearance behind the blade to facilitate cleaning. Stainless steel protection ring around the blade. Enveloping and protective built-in sharpener. Anti-infiltration seal. Ideal for restaurants, hotels, catering, supermarkets.



ROYAL 350











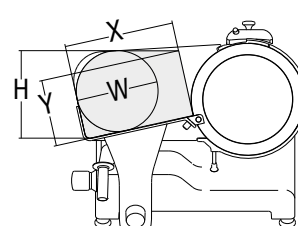
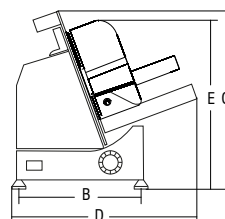
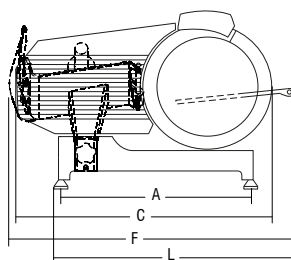









ROYAL LUX 350

OPZIONI/OPTIONALS



Quantanium



																				
ROYAL 350	350/14"	370/0,50	14	315	280x255	510	385	700	565	485	730	615	640	270	200	255	240	32,5	760x650x570	39,5
ROYAL LUX 350	350/14"	370/0,50	14	310	280x255	510	385	700	565	485	735	615	640	270	190	240	230	33	760x650x570	40

HEAVY DUTY - Gear



MAX G 300 - 350 - 370

Affettatrici a gravità in alluminio anodizzato.
Lama in acciaio 100CR6 disponibile con diametro di 300mm, 350mm e 370mm.
Anello di protezione in acciaio inossidabile. Trasmissione ad ingranaggi, perfetta anche per il taglio dei prodotti più duri.

Gravity slicers in anodized aluminum casting construction.
100CR6 steel blade available in 300mm, 350mm and 370mm diameter. Stainless steel protection ring. Gear transmission, also perfect for cutting harder products.



OPZIONI/OPTIONALS



Quantanium

+ Configurazione Quantanium opzionale
Optional Quantanium configuration

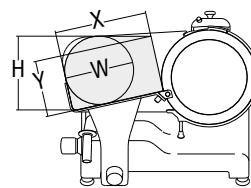
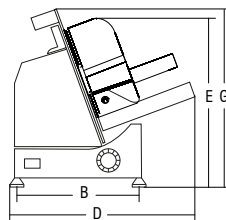
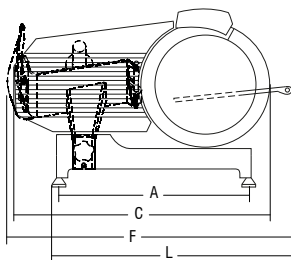

	mm-inch	watt-Hp	mm	mm	mm	mm	mm	mm	mm	mm	mm	mm	mm	mm	mm	mm	kg	mm	kg	
MAX G 300	300/12"	370/0,50	15	340	280x255	575	425	710	575	480	785	600	660	250	170	230	210	38	860x810x820	53
MAX G 350	350/14"	370/0,50	15	340	295x285	575	425	710	575	500	790	620	660	300	200	270	250	41	860x810x820	56
MAX G 370	370/15"	370/0,50	15	340	295x285	575	425	710	575	510	790	620	660	290	210	280	260	41,5	860x810x820	56,5

HEAVY DUTY



MONDIAL 300 - 350

MONDIAL è un'affettatrice a gravità con uscita libera della fetta: l'area dietro la lama è completamente libera. Conosciuta e molto apprezzata in tutto il mondo per il suo design unico e inimitabile, questa macchina offre una maggiore capacità di taglio, regolazione esatta dello spessore e scorrimento dolce del carrello. Ideale per salumerie, supermercati, ristoranti e grandi cucine. Due misure disponibili: con lama da 300mm o 350mm.

MONDIAL is a gravity slicer with clear slice exit design: the entire area behind the blade is completely free. Well known and appreciated all over the world for its unique and unbeatable design, this slicer offers larger cut capacity, exact thickness regulation and smooth carriage stroke. Ideal machine for delicatessen, supermarkets and large size kitchens. Two available sizes: with 300mm or 350mm blade.



- ✔ **Uscita libera della fetta e ampia area di raccolta**
- ✔ Costruzione robusta per fette precise
- ✔ Alta protezione contro l'umidità
- ✔ Grande capacità di taglio

- ✔ **Clear slice exit and wide sliced product storage area**
- ✔ Sturdy construction for precise slices
- ✔ High protection against internal component moisture
- ✔ Large cut capacity

OPZIONI

- + piatto per taglio inclinato

OPTIONALS

- + inclined product holder

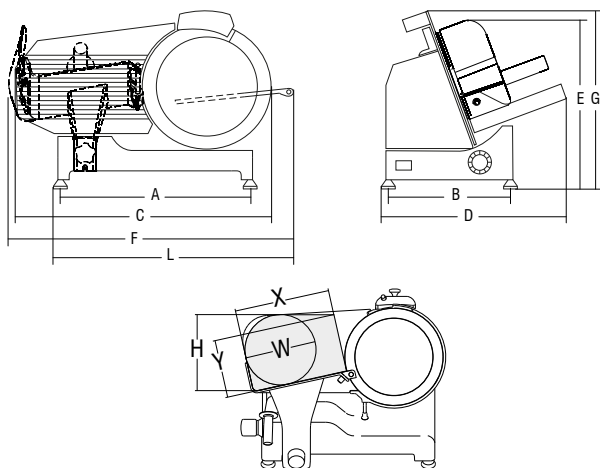

OPZIONI/OPTIONALS



Piatto per taglio inclinato
Inclined product holder



Estrattore lama SBR
SBR blade removal tool

	mm-inch	watt-Hp	mm	mm	mm	mm	mm	mm	mm	mm	mm	mm	mm	mm	mm	mm	kg	mm	kg	
MONDIAL 300	300/12"	270/0,37	30	315	280x300	540	360	650	540	460	650	460	642	190	160	220	400	30	790x640x580	37
MONDIAL 350	350/14"	270/0,37	30	315	280x300	540	360	700	540	500	700	500	692	250	160	270	400	33	790x640x580	41

HEAVY DUTY - Stainless steel gear



STRATOS 350

Affettatrice Heavy Duty a gravità.
 Corpo dal design moderno e accattivante, realizzato in profilo di alluminio, che garantisce produttività, precisione, polivalenza, sicurezza e igiene.
 Struttura solida che garantisce le massime prestazioni nella sua categoria. Ideale per carichi di lavoro ad alto volume in supermercati e ipermercati e in hotel e aziende di catering.
 Il motore posizionato sotto al carrello, permette di avere un ampio spazio di uscita della fetta.
 Tutte le superfici esterne sono in alluminio anodizzato, tranne il piatto realizzato in acciaio inox, con spondina di serie.
 Spazio di appoggio prodotto ampio e facilmente pulibile
 Lama da 350mm in lega di acciaio al cromo temprato di alta qualità.
 Motore ad uso continuo potente e silenzioso.
 Comandi elettrici isolati con sicurezza No Volt Release.
 Trasmissione a cinghia: lunga durata, nessuna manutenzione.
 Movimento scorrevole del carrello anche con prodotti pesanti.
 Grandi dimensioni per prestazioni al top e facilità di pulizia.
 Estrattore lama di serie.
 Design elegante per un'affettatrice che non passa inosservata.

*Heavy-duty gravity slicer.
 A modern and attractive body design, crafted from aluminum profiles, ensures productivity, precision, versatility, safety, and hygiene.
 Solid structure that guarantees the highest performance in its category. Ideal for high-volume workloads in supermarkets and hypermarkets, as well as hotels and catering companies.
 The motor positioned under the carriage provides ample space for slice output.
 All external surfaces are made of anodized aluminum, except for the stainless steel plate, which comes standard with a guard.
 Ample, easy-to-clean product support
 350 mm blade made of high-quality hardened chromium steel alloy.
 Powerful and quiet continuous-use motor.
 Insulated electrical controls with No Volt Release safety device. Belt drive: long-lasting, maintenance-free. Smooth carriage movement even with heavy products. Large dimensions for top performance and easy cleaning. Blade extractor included.
 Elegant design for a slicer that stands out.*

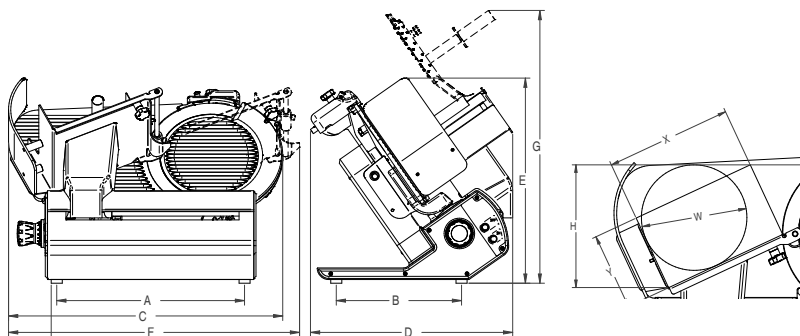
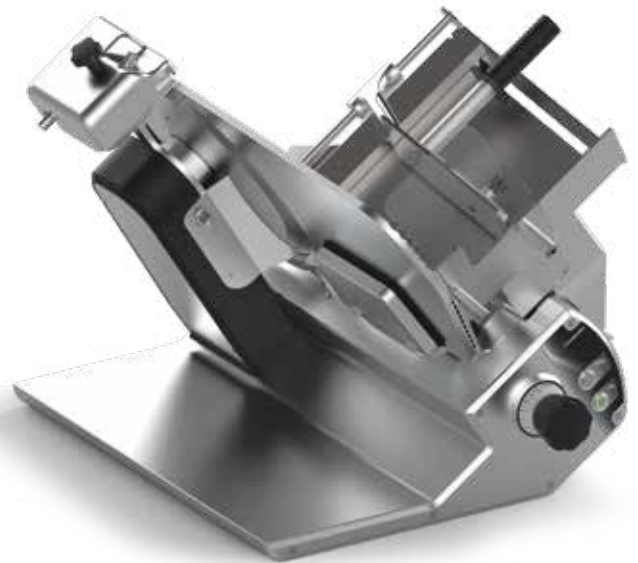

OPZIONI/OPTIONALS



Piatto per taglio inclinato
 Inclined product holder

	A	B	C	D	E	F	G	L	X	Y	H	W							
STRATOS 350	350/14"	370 / 0,5	25	350	280x300	510	340	745	550	570	790	740	675	280	170	275	235		

LA TECNOLOGIA PIÙ INNOVATIVA UNITA ALLA PRECISIONE ARTIGIANALE
THE SMARTEST TECHNOLOGY COMBINED WITH THE HANDCRAFT ACCURACY



✔ **PRODUTTIVITÀ**
 Potente motore con raffreddamento ad aria forzata
 Trasmissione a cinghia
 Grande capacità di taglio.

✔ **PRECISIONE**
 Struttura robusta
 Trasmissione a tenuta stagna
 Movimento vela progressivo dei primi 3 mm di apertura, garantisce una maggiore precisione di regolazione taglio delle fette sottili

✔ **USO POLIVALENTE**
 Efficace con tutti i tipi di alimenti

✔ **SICUREZZA**
 100% conforme alle norme di sicurezza internazionali

✔ **IGIENE**
 Pulizia completa e rapida grazie al design rivoluzionario:
 Spazi liberi
 Facilmente accessibile in tutte le parti
 Superfici esterne in alluminio anodizzato
 Piatto in acciaio inox
 Elevata protezione contro l'umidità
 Assenza di spigoli e cavità

✔ **DETTAGLI DI ALTA QUALITÀ**
 Comandi, in acciaio inox IP 67
 Manopole in materiale polimerico per garantire un'impugnatura confortevole e sicura

✔ **PRODUCTIVITY**
 Powerful motor with forced air cooling
 Belt-drive transmission
 Big cut capacity

✔ **PRECISION**
 Robust and oversized structure
 Gasket sealed transmission
 Adjustable slicer table movement in the first 3 mm of opening, guarantees higher cutting precision

✔ **MULTI-PURPOSE USE**
 Effective with all types of food

✔ **SAFETY**
 100% international safety rules compliant

✔ **HYGIENE**
 Quick and complete cleaning thanks to the revolutionary design:
 Free spaces
 Easily accessible on all parts
 Anodized aluminum exterior surfaces
 Stainless steel plate
 Highly protected against moisture
 No sharp edges or cavities

✔ **TOP QUALITY DETAILS**
 Controls, in IP 67 stainless steel
 Polymer knobs for a comfortable and secure grip



MEDIUM DUTY



ELEKTRA 300

Affettatrice verticale in alluminio anodizzato con lama in acciaio C45 dal diametro di 300mm, con anello di protezione in alluminio. L'affettatrice più amata dai salumieri! Disponibile anche l'accattivante versione in rosso.
 Perfetta per il taglio di salumi, carne, verdure. Ideale per salumerie, ristoranti, bar.

Vertical slicer in anodized aluminum casting construction with a 300mm diameter C45 steel blade. CE Version with aluminum protection ring around the blade. Is the most loved slicer in deli-shop! Also available in the charming red version! Perfect for cutting cold cuts, meat, vegetables. Ideal for deli-shops, restaurants, bars.



OPZIONI/OPTIONALS



Colore rosso
Red color

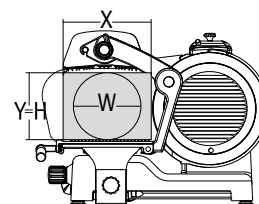
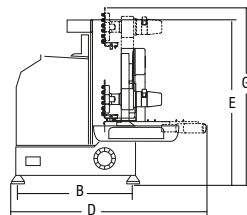
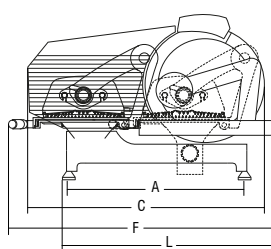

	mm-inch	watt-Hp	mm	mm	mm	mm	mm	mm	mm	mm	mm	mm	mm	mm	mm	mm	kg	mm	kg	
ELEKTRA G 300	300/12"	210/0,28	16	275	250x265	455	345	575	575	480	725	700	565	255	205	205	205	25,5	730x590x530	30



MAX SV 350 - 370 CV 350 - 370

Affettatrici verticali in alluminio anodizzato con apposito piatto pensato per il taglio dei salumi. Lama in acciaio 100CR6 disponibile con diametro di 350mm e 370mm. Anello di protezione in acciaio inossidabile. Trasmissione ad ingranaggi, perfetta anche per il taglio dei prodotti più duri. Le affettatrici verticali sono ideali per tagliare prodotti di grandi dimensioni.

Vertical slicers in anodized aluminum casting construction with a special food carriage designed for cutting cured meat.

100CR6 steel blade available in 350mm and 370mm diameter. Stainless steel protection ring. Gear transmission, also perfect for cutting harder products. Vertical slicers are ideal for cutting large products.









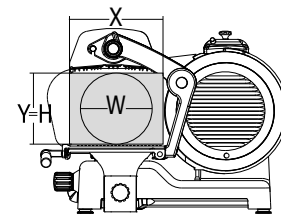
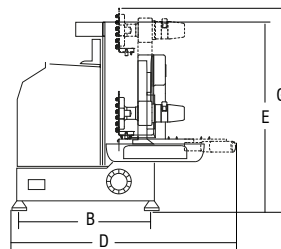
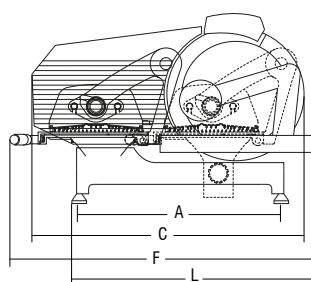













MAX SV 350 - 370



MAX CV 350 - 370



																						
	mm-inch	watt-Hp	mm	mm	mm	mm	mm	mm	mm	mm	mm	mm	mm	mm	mm	mm	mm	mm	mm	kg	mm	kg
MAX SV 350	350/14"	370/0,50	18	340	300x295	575	425	710	635	600	820	640	690	300	255	255	255	255	45,5	860x810x820	60,5	
MAX SV 370	370/15"	370/0,50	18	340	300x295	575	425	710	635	610	820	640	690	290	260	260	260	260	46	860x810x820	61	
MAX CV 350	350/14"	370/0,50	18	340	360x300	575	425	710	650	600	775	595	670	285	260	260	265	265	45,5	860x810x820	60,5	
MAX CV 370	370/15"	370/0,50	18	340	360x300	575	425	710	650	610	775	605	670	285	270	270	275	275	46	860x810x820	61	

HEAVY DUTY



BETA CV 300 - 350

BETA CV è un'affettatrice verticale con uscita libera della fetta: l'area dietro la lama è completamente libera. Spessore delle fette regolabile da 0 a 30mm.

Un carpaccio sottile o una bistecca spessa sono semplici da gestire con Beta. Facile e sicura da pulire anche dopo 10 ore di utilizzo. Indicata per macellerie, supermercati e grandi cucine. Due misure disponibili: con lama da 300mm o 350mm.









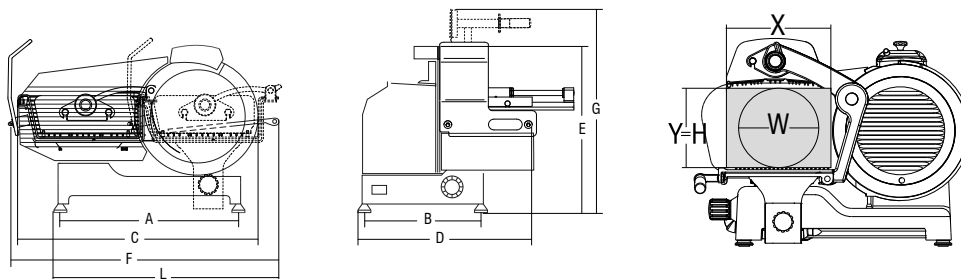







BETA CV is a vertical meat slicer with clear slice exit design: the entire area behind the blade is completely free. It is possible to cut slices of thickness up to 30 mm. Thin carpaccio or thick steaks become an easy job with Beta. Easy and safe cleaning after 10 hours of hard work. Ideal machine for butcher shops, supermarkets and large size kitchens. Two available sizes: with 300mm or 350mm blade.



- ✓ **Uscita libera della fetta**
- ✓ Alta protezione contro l'umidità
- ✓ Costruzione robusta per fette precise
- ✓ Ampio carrello porta prodotto
- ✓ Grande capacità di taglio
- ✓ Ampia area di raccolta fette
- ✓ Motore potente e silenzioso

- ✓ **Clear slice exit**
- ✓ High protection against humidity
- ✓ Sturdy construction for precise slices
- ✓ Large product holder
- ✓ Large cut capacity
- ✓ Wide slice collection area
- ✓ Powerful and noiseless motor



																				
	mm-inch	watt-Hp	mm	mm	mm	mm	mm	mm	mm	mm	mm	mm	mm	mm	mm	mm	mm	kg	mm	kg
BETA CV 300	300/12"	270/0,37	30	330	320x380	510	350	660	690	515	840	640	515	330	160	280	470	35	830x730x710	43
BETA CV 350	350/14"	270/0,37	30	330	320x380	510	350	660	690	555	840	640	515	330	160	280	470	36	830x730x710	44

HEAVY DUTY



BETA SV 300 - 350

BETA SV è un'affettatrice verticale con uscita libera della fetta: l'area dietro la lama è completamente libera.

Ideale per il taglio sottile di prosciutti e salumi italiani.

Indicata per salumerie, ristoranti e grandi cucine.

Il braccio stringisalumi garantisce la stabilità del prodotto da affettare.

Ampio vassoio in acciaio inox per la raccolta delle fette, asportabile per la pulizia.

Due misure disponibili: con lama da 300mm o 350mm.

BETA SV is a vertical slicer with clear slice exit design: the entire area behind the blade is completely free.

It is the most suited slicer for thin cutting of prosciutto, italian hams, cold-cuts and processed meat.

Ideal machine for delicatessen, supermarkets and large size kitchens.

The clutch coupled foodpusher arm guarantees a stable hold of the product to be sliced.

Wide receiving stainless steel tray, removable for cleaning purposes.

Two available sizes: with 300mm or 350mm blade.



OPZIONI

 piatto per taglio inclinato

OPTIONALS



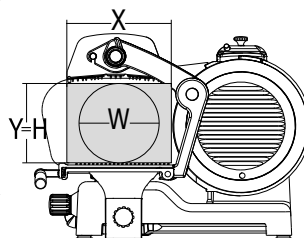
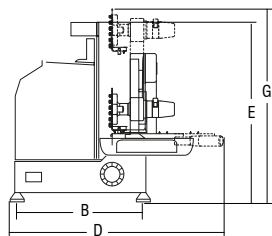
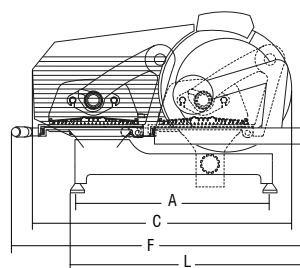















 inclined product holder



OPZIONI/OPTIONALS



Estrattore lama SBR
SBR blade removal tool

																				
	mm-inch	watt-Hp	mm	mm	mm	mm	mm	mm	mm	mm	mm	mm	mm	mm	mm	mm	kg	mm	kg	
BETA SV 300	300/12"	270/0,37	30	310	310x320	510	350	700	660	515	720	585	540	435	510	530	400	30	830x730x710	37
BETA SV 350	350/14"	270/0,37	30	310	310x320	510	350	700	660	555	720	585	540	435	510	530	400	33	830x730x710	41

PREPARAZIONE FOOD PREPARATION



Selezione di macchine per la ristorazione e la macelleria, progettate per ottimizzare il lavoro e garantire risultati di alta qualità. Questa gamma di attrezzature racchiude macchine per il confezionamento e la cottura sottovuoto, tagliaverdure, cutter, frullatori ad immersione, tritacarne e segaossi. Sono tutte realizzate con materiali robusti e tecnologie innovative. Le nostre macchine sono ideali per soddisfare le esigenze di ristoranti, macellerie e attività di catering, assicurando efficienza, sicurezza e facilità d'uso.

Selection of catering and butcher machines, designed to optimize work and guarantee high-quality results. This range of equipment includes vacuum packaging and cooking machines, vegetable cutters, cutters, immersion blenders, mincers and bone saws. They are all made with robust materials and innovative technologies. Our machines are ideal for meeting the needs of restaurants, butchers and catering businesses, ensuring efficiency, safety and ease of use.



SV 2K

Apparecchio per la cottura sottovuoto

Riscaldatore termoregolato ad alta precisione. Visualizzatore di temperatura e tempo esercizio. 25 programmi memorizzabili. Partenza posticipata programmabile. Struttura in acciaio inox IP X3. Profondità di lavoro max 16,5 cm. Dispositivo di protezione automatico in caso di utilizzo a secco. Ventola di circolazione per favorire una ottima miscelazione del prodotto. Dispositivo di blocco motore se rilevata sovratensione e sovratemperatura.

Sous vide cooking system

High precision warmer with temperature control. Working temperature display. 25 storable programs. Programmable postponed departure. IP X3 protection rated stainless steel structure. Can be applied to the container by means of a clamp. (max depth 16,5 cm). Protection device switches off the warmer in case of accidental use without liquid. Circulating pump to help the best product mixing. Temperature sensor to prevent overheating.



OPZIONI/OPTIONALS

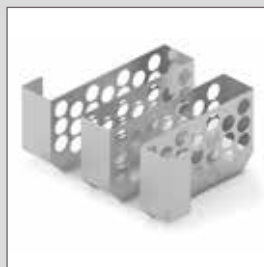

+ Divisorio buste sottovuoto
Vacuum bags divider









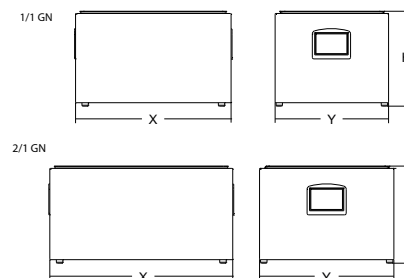
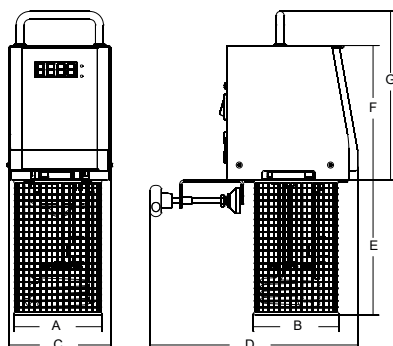







+ Vasca 1/1 GN inox con coperchio
1/1 GN s/steel container with lid



+ Vasca 2/1 GN inox con coperchio
2/1 GN s/steel container with lid



															
	watt	1ph	°C	lt	lt	mm	mm	mm	mm	mm	mm	mm	kg	mm	kg
SV 2K	2.000	1ph	24÷99	-	-	110	105	130	260	170	170	210	4.5	330x455x240	5.5
1/1 GN	-	-	-	27	22	565	360	230	-	-	-	-	7.7	720x500x350	11.5
2/1 GN	-	-	-	57.5	43	650	530	230	-	-	-	-	13	750x650x400	16



BREEZE M 31 M mc 8 - 41 M mc 20

Campana a grande sviluppo di volume
Barra saldante facilmente rimovibile
Comandi manuali con regolazione veloce e intuitiva del tempo di vuoto e saldatura
Estrema facilità di pulizia grazie alla planarità del piano di appoggio prodotto. Sollevamento coperchio automatico a mezzo di pistoncini pneumatici. Supporto per buste con liquidi
Vacuometro analogico

*Great volume transparent lid
Easily removable sealing bar
Manual controls with fast and intuitive adjustment of vacuum and sealing time
Extremely easy to clean thanks to the flatness of the chamber. Automatic lifting the lid by means of pneumatic pistons. Support for vacuum bags with liquids
Analogic vacuum gauge*



BREEZE 31 M mc 8



BREEZE 41 M mc 20

OPZIONI/OPTIONALS



+ Tubo per aspirazione esterna
External suction hose



+ Contenitori GN 1/1 - 1/2 (h.100/150) con coperchio inox
Containers GN 1/1 - 1/2 (h.100/150) with s/steel cover









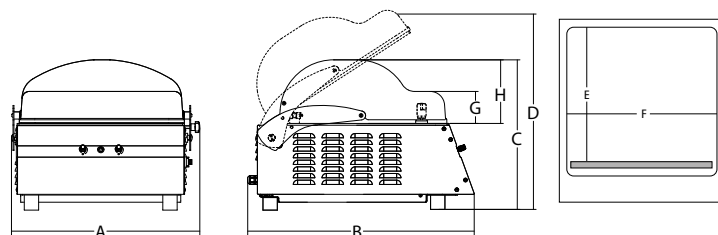





0-100% vuoto / vacuum



+ Contenitori GN 1/1 - 1/2 - 1/3 (h.100/150) con coperchio in Tritan
Containers GN 1/1 - 1/2 - 1/3 (h.100/150) with cover in Tritan

0-80% vuoto / vacuum



																	
	kw	lph	mc/h	mm	mm	mm	mm	mm	mm	mm	mm	mm	kg	mm	kg		
BREEZE 31 M mc 8	0.35	1ph	8	310	340x360	h.185	433	571	404	523	334	340	95	170	36	720x570x770	48
BREEZE 41 M mc 20	0.75	1ph	20	410	430x410	h.195	525	631	417	544	390	430	95	180	54	760x640x770	66



BREEZE

31 mc 8 - 41 mc 12 - 41 mc 20

Lo straordinario design riduce l'ingombro della macchina e migliora la praticità.

Campana di grande volume ad iniezione in Tritan®. Barra saldante facilmente rimovibile.

Estrema facilità di pulizia grazie alla perfetta planarità del piano di appoggio prodotto realizzato in acciaio inox AISI 304 spessore 5 mm. Sollevamento coperchio automatico a mezzo di pistoncini pneumatici. Supporto per buste con liquidi.

The extraordinary design reduces the footprint of the machine and improves practicality.

Great volume chamber with lid made of injected Tritan®. Easily removable sealing bar.

Extremely easy to clean thanks to the perfect flatness of the product support surface made of 5mm thick AISI 304 stainless steel. Automatic lid lifting by means of pneumatic pistons. Support for bags with liquid.



BREEZE 31 mc 8



BREEZE 41 mc 12

OPZIONI/OPTIONALS



+ Ripiano in plexiglass trasparente
Plexiglass support



+ Tubo per aspirazione esterna
External suction hose



+ Contenitori GN 1/1 - 1/2 (h.100/150) con coperchio inox
Containers GN 1/1 - 1/2 (h.100/150) with s/steel cover









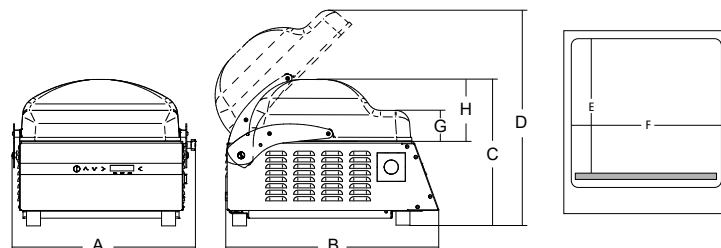





0-100% vuoto / vacuum



+ Contenitori GN 1/1 - 1/3 (h.100/150) con coperchio in Tritan
Containers GN 1/1 - 1/3 (h.100/150) with cover in Tritan

0-80% vuoto / vacuum



																
	kw		mc/h	mm	mm	mm	mm	mm	mm	mm	mm	mm	kg	mm	kg	
BREEZE 31 mc 8	0.35	1ph	8	310	340x360 h.160	402	525	408	587	334	340	95	170	38	720x570x770	48
BREEZE 41 mc 12	0.45	1ph	12	410	430x410 h.170	493	585	422	630	390	430	99	180	54	760x640x770	64
BREEZE 41 mc 20	0.75	1ph	20	410	430x410 h.170	493	585	422	630	390	430	99	180	56	760x640x770	66



GHIBLI

31 mc 8 P - 41 mc 20 P - 51 mc 20 P - 41x2 mc 20 P

Lo straordinario design riduce l'ingombro della macchina e migliora ergonomia e praticità. Campana di grande volume in plexiglass termoformato di grosso spessore sui mod. 51 e 41x2, ad iniezione in Tritan® su mod. 31 e 41. Barra saldante facilmente rimovibile. Estrema facilità di pulizia grazie alla planarità del piano di appoggio prodotto, realizzato in acciaio inox AISI 304 spessore 5 mm. Sollevamento coperchio automatico a mezzo di pistoncini pneumatici. Supporto per buste con liquidi incluso

The extraordinary design reduces the footprint of the machine and improves ergonomics and usability. Great volume lids are made of thermoformed plexiglass on mod. 51 and 41x2, while on mod. 31 and 41 are made of injected Tritan®. Easily removable sealing bar. Extremely easy to clean thanks to the flatness of the product tray, made of AISI 304 stainless steel 5 mm thick. Lid lifts up automatically with pneumatic pistons. Including taper support for bags with liquid.



GHIBLI 31 mc 8 P



GHIBLI 41 mc 20 P



GHIBLI 51 mc 20 P



GHIBLI 41x2 mc 20 P



Stampante termica automatica per data, ora e dati confezionamento (di serie)
 Built in thermal label printer to fix date, time and packing specifications on every single bag (standard)

OPZIONI/OPTIONS



+ Tubo per aspirazione esterna
 External suction hose



+ Impianto per gas inerte (MAP).
 Gas flush system option (MAP)



+ **SanO3** sistema integrato e automatico di sanificazione con Ozono
SanO3 - integrated and automated sanitizing system with Ozone

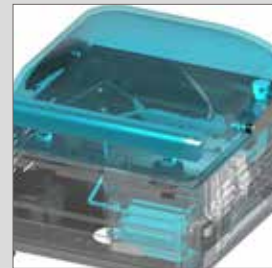

+ **A.O.R.** cambio olio automatico
A.O.R. - Automatic Oil Replacement



+ Ripiano in plexiglass trasparente
 Plexiglass support









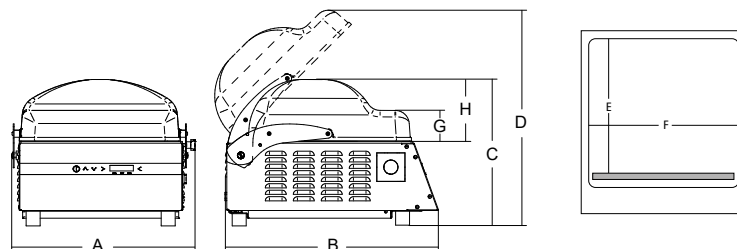









+ Contenitori GN 1/1 - 1/2 (h.100/150) con coperchio inox
 Containers GN 1/1 - 1/2 (h.100/150) with s/steel cover
 0-100% vuoto / vacuum



+ Contenitori GN 1/1 - 1/2 - 1/3 (h.100/150) con coperchio in Tritan
 Containers GN 1/1 - 1/2 - 1/3 (h.100/150) with cover in Tritan
 0-80% vuoto / vacuum



																
	kw	lph	mc/h	mm	mm	mm	mm	mm	mm	mm	mm	mm	mm	kg	mm	kg
GHIBLI 31 mc 8 P	0.35	1ph	8	310	340x360 h.130	402	525	360	480	333,4	340	85	140	46	720x570x770	57
GHIBLI 41 mc 20 P	0.75	1ph	20	410	430x410 h.140	493	585	370	542	390	430	85	150	56	760x640x770	67
GHIBLI 51 mc 20 P	0.75	1ph	20	510	540x430 h.190	609	640	420	605	430	540	90	200	70	840x870x750	84
GHIBLI 41x2 mc 20 P	0.75	1ph	20	410x2	545x460 h.190	609	640	420	605	424	428	90	200	71	840x870x750	85



VEG 500

Realizzazione in lega di alluminio e acciaio inox. Motore ventilato per uso continuo. Design estremamente compatto per una migliore gestione degli spazi in cucina. L'esclusivo sistema a caduta diretta del prodotto permette di lavorare anche prodotti morbidi e delicati come mozzarella e altri formaggi. Sicurezza garantita da 3 microinterruttori: su leva, coperchio e vasca. Vasca raccoglietorte con interblocco in dotazione.

Aluminium alloy and S/S construction. Ventilated motor for continuous operation. Thanks to its compact design the vegetable cutter is easy to install inside every kitchen. The exclusive feeding system makes it easy to process also soft products like mozzarella cheese. Safe operation is ensured by interlock switches on product pusher, lid and collecting tray. Slice collection tray with interlock standard.

OPZIONI

- + Ampia disponibilità di dischi per tutte le applicazioni
- + Coperchio inox lavabile in lavastoviglie.

OPTIONALS

- + Large number of discs available for every purpose.
- + Version with dishwashing safe S/S lid available..



OPZIONI/OPTIONALS

Dischi fette / Slicing discs



Disco regolabile / Adjustable disc



Dischi bastoncini / Discs sticks



Dischi cubetti / Dicing discs



Dischi per sfilacciare / Discs for shredding









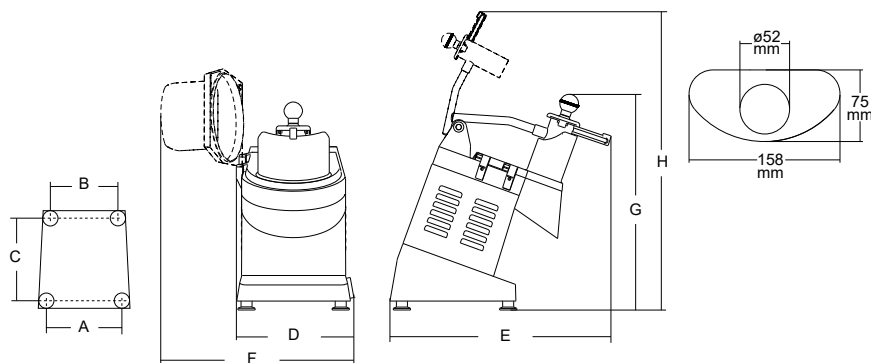







Dischi grattugia / Grating discs



- + Disco regolabile DF1-7 che permette di tagliare fette di spessore da 1 a 7 mm a piacere
DF1-7 adjustable disc allows you to cut slices of thickness from 1 to 7 mm as desired



														
	watt/HP	r.p.m.	mm	mm	mm	mm	mm	mm	mm	mm	mm	kg	mm	kg
VEG 500	515/0.7	1ph/3ph	300	225	195	255	280	510	400	510	770	18.5	720x350x500	22

CUTTER
BOWL CUTTER



MARLIN 4V - 6V - 9V

Robusta struttura in alluminio pressofuso ed estruso. Motore e vasca affiancati che permettono di isolare dal calore il prodotto lavorato. Vasche in acciaio inox con fondo termico e manici. Motori ventilati ad alto rendimento per uso continuo. Robusti coltelli a lame curve in acciaio temprato da coltelleria. Microinterruttore di sicurezza su coperchio. Microinterruttore su leva. Coperchio in Tritan trasparente che permette ottima visibilità durante la lavorazione. Foro di aggiunta ingredienti su coperchio. Spatola raschiatrice per la pulizia di vasca e coperchio durante la lavorazione. In dotazione: spatola e piastra affilatura lame. Variatore di velocità stabilizzato.

Sturdy body in die-cast and extruded aluminium. Motor and tank side-by-side, allowing the product to be isolated from the heat. S/S bowl with handles and heavy bottom. High efficiency ventilated motor for continuous operation. Strong cutlery steel knives. Safety micro-switch on lid. Micro-switch on lever. Lid in transparent Tritan allowing excellent visibility during processing. Lid with opening to add ingredients during operation. Scraper spatula for cleaning the tank and lid during processing. Standard: spatula and sharpening stones. Stabilised speed variator.



MARLIN 4 V



MARLIN 6 V



MARLIN 9 V

IN DOTAZIONE / STANDARD



Lama di serie
Standard blade



Spatola
Spatula



Piastra affilatura
Blade sharpener plate

OPZIONI / OPTIONALS



Lame impasto
Dough blades



Lame forate
Perforated blades





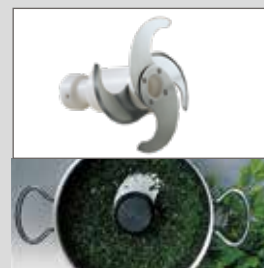



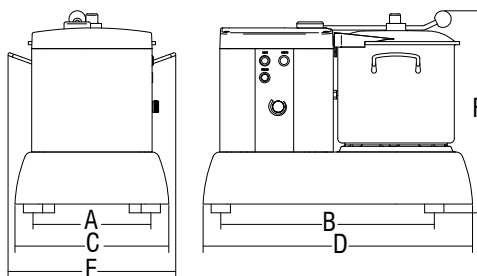

Lame dentate
Serrated blades



Lame pesto
pesto blades



						A	B	C	D	E	F			
	watt/Hp	lph	lt	lt	r.p.m.	mm	mm	mm	mm	mm	mm	kg	mm	kg
MARLIN 4 V	600/0.8	1ph	3.3	1.5	1600 ÷ 2500	185	369	251	457	296	300	13.5	300x505x370	16
MARLIN 6 V	600/0.8	1ph	5.3	3.1	1600 ÷ 2500	185	369	251	457	304	362	14.5	300x505x430	17
MARLIN 9 V	1200/1.6	1ph	9.4	5.4	500 ÷ 2000	244	443	319	560	348	420	23	365x600x485	26

MISTRAL S









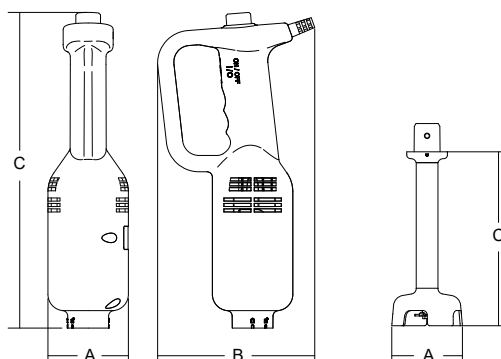

Efficiente sistema di raffreddamento del motore per un utilizzo prolungato.
Robusta ma leggera struttura portante in ABS caricato a vetro.
Pratica ed ergonomica impugnatura.
Velocità variabile.
Macchina protetta con grado IP x3.
Rapido sistema di aggancio asta.
Coltello a tre lame in acciaio da coltelleria.

*Highly effective cooling system.
Sturdy, lightweight ABS Glass Filled frame.
Practical and ergonomic handle.
Variable speed controls.
The mixer is IPX3 protected.
Quick coupling system.
Knife with three blades in hardened cutlery steel.*



 Pratico sgancio asta
Quick coupling system



											
	watt/Hp	lph	r.p.m.	lt	mm	mm	mm	mm	kg	mm	kg
MISTRAL S	200/0.27	1ph	2.000÷12.500	15	74	145	290	-	1.1	225x560x140	2
Asta 16	-	-	-	-	ø 65	-	160	130	0.2	-	-



MISTRAL M

Efficiente sistema di raffreddamento motore.
Robusta ma leggera struttura portante in ABS caricato a vetro.
Pratica ed ergonomica impugnatura.
Pulsante protetto per prevenire l'accensione accidentale.
Comandi VT (Variotronic): variatore di velocità stabilizzato con controllo di potenza.
Macchina protetta con grado IP x3.
Rapido sistema di aggancio asta.
Disponibili aste da 25 e 35 cm. Coltello a tre lame in acciaio da coltelleria. Frusta con sistema di ingranaggi in metallo. Fruste inox smontabili e pulibili in lavastoviglie.

*Efficient engine cooling system. Sturdy, lightweight ABS Glass Filled frame.
Practical and ergonomic handle.
Protected button to prevent accidental activation.
Commands VT (Variotronic): speed control with stabilizer.
The mixer is IPX3 protected. Quick coupling system.
Shafts available in 25 and 35 cm.
Hardened cutlery steel knives.
Whisk with metal gear system. Stainless steel whisks that can be disassembled and cleaned in the dishwasher.*











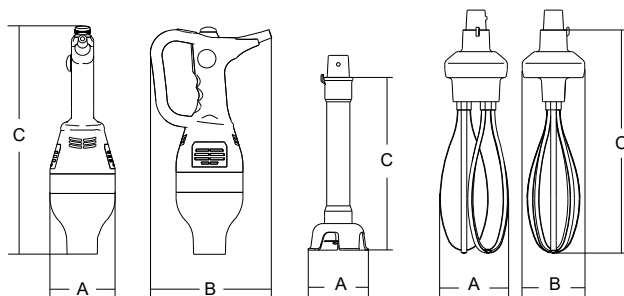



OPZIONI

- Supporto pentola
- Supporto a muro
- Frusta
- Espositore inox

OPTIONALS

- Pot support
- wall attachment
- whisk
- Display stand



												
	watt/Hp	lph	r.p.m.	r.p.m.	lt	mm	mm	mm	mm	kg	mm	kg
MISTRAL M	360/0.50	1ph	350+2.450	2.300+16.000	70	100	182	348	-	2.5	440x330x150	3.5
Asta 25	-	-	-	-	-	ø 94	-	250	190	0.5	320x210x220	1
Asta 35	-	-	-	-	-	ø 94	-	320	290	1	490x230x150	1.5
Frusta	-	-	-	-	-	106	113	348	165	2	520x210x250	3

FRULLATORI AD IMMERSIONE
HAND-HELD MIXERS



MISTRAL L

Efficiente sistema di raffreddamento motore.
Robusta ma leggera struttura portante in ABS caricato a vetro.
Pratica ed ergonomica impugnatura.
Pulsante protetto per prevenire l'accensione accidentale.
Comandi VT (Variotronic): variatore di velocità stabilizzato con controllo di potenza.
Macchina protetta con grado IP x3.
Rapido sistema di aggancio asta.
Disponibili aste da 35 e 45 cm.
Coltello a tre lame in acciaio da coltelleria.
Frusta con sistema di ingranaggi in metallo.
Fruste inox smontabili e pulibili in lavastoviglie.

*Efficient engine cooling system.
Sturdy, lightweight ABS Glass Filled frame.
Practical and ergonomic handle.
Protected button to prevent accidental activation.
Commands VT (Variotronic): speed control with stabilizer.
The mixer is IPX3 protected.
Quick coupling system.
Shafts available in 35 and 45 cm.
Hardened cutlery steel knives.
Whisk with metal gearing.
Stainless steel whisks that can be disassembled and cleaned in the dishwasher.*

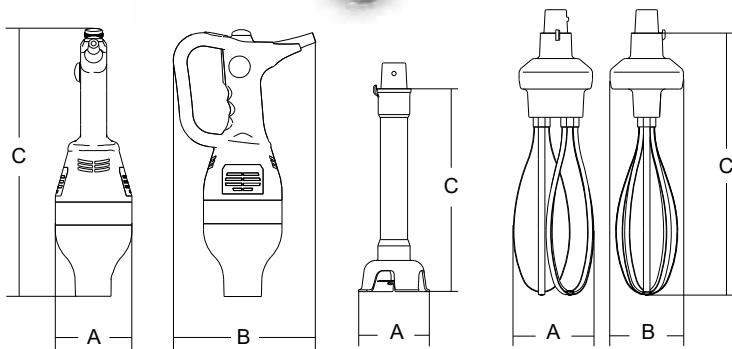







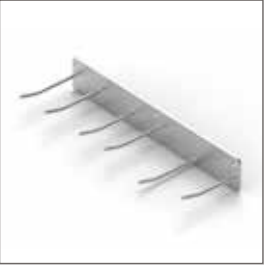

OPZIONI/OPTIONALS



Supporto pentola
Bowl support



Supporto a muro
Wall support

						A	B	C	D			
	watt/Hp	1ph	r.p.m.	r.p.m.	lt	mm	mm	mm	mm	kg	mm	kg
MISTRAL L	750/1	1ph	350÷1800	2.200÷11.500	300	125	190	390	-	4	570x300x180	4.5
Asta 35	-	-	-	-	-	ø100	-	415	350	1	490x230x150	1.5
Asta 45	-	-	-	-	-	ø100	-	515	450	1.5	590x230x150	2
Frusta	-	-	-	-	-	117	113	385	200	2	520x210x250	2.5

GRATTUGIE
CHEESE GRATER



LYNX CG

Robusta struttura in alluminio anodizzato e fianchi in acciaio inox AISI 304. Motore ventilato. Bocca grattugia smontabile in lega di alluminio lucidata e anodizzata. Rullo grattugia inox. Microinterruttore di sicurezza su vaschetta raccolta formaggio e leva (CE). Comandi IP54 con NVR (CE).

Sturdy anodized aluminum frame and AISI 304 stainless steel sides. Ventilated motor. Removable grater head in polished and anodized aluminum alloy. Steel grating drum. Safety microswitches on handle and receiving tray (CE). IP54 protection rated controls and NVR device (CE).

PANTHER CG

Corpo in alluminio anodizzato e fianchi in acciaio inox AISI 304. Generoso motore ventilato. Bocca grattugia in alluminio brillantato di grande capienza. Capiente e pratica vasca di raccolta prodotto in plexiglass trasparente. Rullo smontabile in acciaio inox. Comandi 24 Volt con NVR (CE). Dispositivo di sicurezza su vaschetta raccolta formaggio e leva (CE).

Anodized aluminum body and AISI 304 stainless steel sides. Generous ventilated motor. Large capacity grater head in polished aluminium. Spacious and practical product collection tank in transparent plexiglass. Removable drum in stainless steel. 24 volt controls and NVR device (CE). Safety microswitch on the receiving tray and the handle (CE).



LYNX CG



PANTHER CG





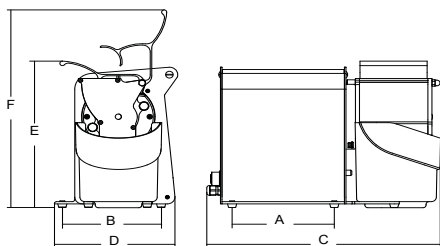



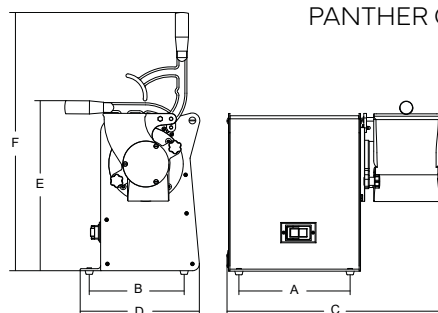





LYNX CG



PANTHER CG



													
	watt/HP		r.p.m.	mm	mm	mm	mm	mm	mm	mm	kg	mm	kg
LYNX CG	370/0.5	1ph	1.400	135x65	202	195	461	243	325	440	15	620x340x450	19
PANTHER CG	1ph - 750/1 3ph - 1.100/1,5	1ph/3ph	1.400	140x80	248	210	487	265	374	579	20	630x430x450	22

LYNX 12 - PANTHER 22

Lynx 12 e Panther 22 sono tritacarne affidabili in grado di lavorare la carne in modo efficiente, sicuro e igienico. Macchine sicure e solide che non vi deluderanno. Ideali per ristoranti, trattorie, pizzerie. Robusta struttura in alluminio anodizzato. Corpo in alluminio anodizzato e fianchi in acciaio inox. Motore ventilato. Riduttore tritacarne ermetico con ingranaggi a bagno d'olio. Ingranaggi elicoidali temperati e rettificati. Piastra e coltello inox. Inversione di marcia di serie. Comandi IP54 con NVR.

Lynx 12 and Panther 22 are reliable mincers that process meat efficiently, safely and hygienically. Safe and solid machines that will not let you down. Ideal for restaurants, pizzerias. Sturdy anodized aluminum structure. Body in anodized aluminum and sides in stainless steel. Ventilated motor. Motor reducer with gears in hermetic oil bath. Hardened and ground helical gears. Stainless steel plate and knife. Standard reversing. IP54 control switch with NVR.



LYNX 12





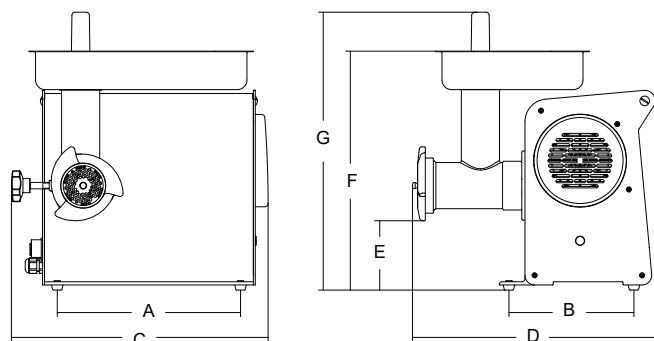











PANTHER 22



OPZIONI/OPTIONALS



														
	watt/HP	lph	Kg/h.	ø mm	mm	mm	mm	mm	mm	mm	mm	kg	mm	kg
LYNX 12	550/0.75	1ph	85	6	286	195	400	373	108	373	434	19	590x410x390	22.5
PANTHER 22	1ph 750/1 3ph 1.100/1.5	1ph/3ph	120	4.5	336	210	460	450	127	411	472	26	570x750x800	36



LYNX 12 inox - PANTHER 22 inox

Lynx 12 inox e Panther 22 inox sono tritacarne affidabili in grado di lavorare la carne in modo efficiente, sicuro e igienico. Macchine sicure e solide che non vi deluderanno. Ideali per ristoranti, trattorie, pizzerie.

Robusta struttura in alluminio anodizzato. Corpo in alluminio anodizzato e fianchi e bocca in acciaio inox. Motore ventilato. Riduttore tritacarne ermetico con ingranaggi a bagno d'olio. Ingranaggi elicoidali temperati e rettificati. Bocca ed elica tritacarne inox. Piastra e coltello inox. Inversione di marcia di serie. Comandi IP54 con NVR.

Lynx 12 inox and Panther 22 inox are reliable mincers that process meat efficiently, safely and hygienically. Safe and solid machines that will not let you down. Ideal for restaurants and pizzerias.

Sturdy anodized aluminum structure. Body and head in anodized aluminum and sides in stainless steel. Ventilated motor. Motor reducer with gears in hermetic oil bath. Hardened and ground helical gears. Stainless steel mincer head and propeller. Stainless steel plate and knife. Standard reversing. IP54 control switch with NVR.

 Bocca in acciaio inox

 Sides in stainless steel



LYNX 12 INOX





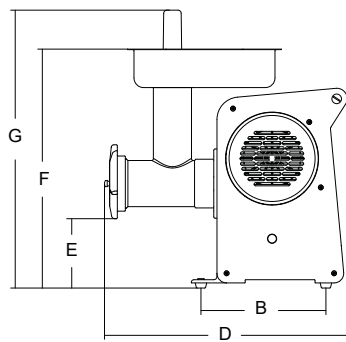
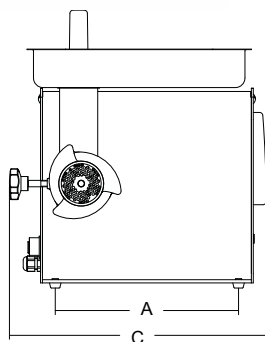











PANTHER 22 INOX



OPZIONI/OPTIONALS



insacchitrice continua con tre imbutoi in polietilene Ø 10 - 18 - 25 (Mod. 22)
stuffer kit, standard polyethylene funnels Ø 10 - 18 - 25 (Mod. 22)

														
	watt/Hp	lph	Kg/h.	ø mm	mm	mm	mm	mm	mm	mm	mm	kg	mm	kg
LINX 12 inox	550/0.75	1ph	85	6	286	195	400	373	108	373	434	19	590x410x390	22.5
PANTHER 22 inox	1ph 750/1 3ph 1.100/1.5	1ph/3ph	120	4.5	336	210	460	450	127	411	472	26	570x750x800	36



TIGER inox 22 - 32

Corpo macchina totalmente in acciaio inox AISI 304. Potenti motori IP 55 autoventilati per uso continuo. Riduttore a bagno d'olio con ingranaggi rettificati. Riduttore con doppio sistema di protezione dai liquidi. Rapido fissaggio bocca senza utensili. Gruppo macinazione completamente in acciaio inox facilmente e totalmente smontabile per pulizia. Tramoggia rimovibile interbloccata (TIGER 32 CE). Comandi 24 Volt IP 54 con inversione (CE).

AISI 304 stainless steel construction. Powerful IP 55 insulated and fan-cooled motors for continuous use. Endless screw motor-reducer running in an oil-bath enables a long service life. Motor-reducer equipped with a double seal for long, trouble-free service. Quick head fixing without tools. Stainless steel head with high output capacity, completely removable for cleaning. Feed tray provided with safety interlock (TIGER 32 CE versions). IP 54 protected, 24 V controls.



TIGER 22 INOX



TIGER 32 INOX

OPZIONI

- + Bocca unger parziale o totale
- + Comandi inox IP 67





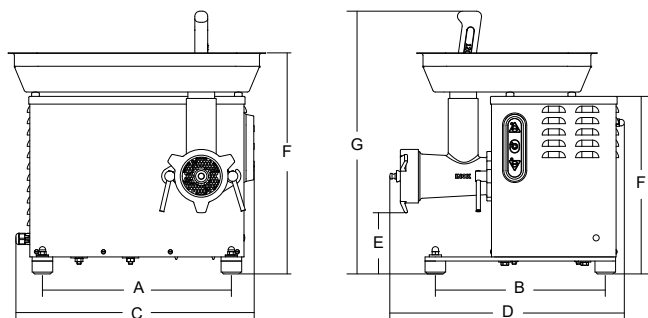









OPTIONALS

- + Partial or total Unger system mincing head
- + Stainless steel IP 67 protected controls.



OPZIONI/OPTIONALS



															
	watt/Hp		kg/h.	∅ mm	mm	mm	mm	mm	mm	mm	mm	mm	kg	mm	kg
TIGER 22 inox	1ph 1100/1.5 3ph 1.472/2	1ph/3ph	300	4.5	367	330	463	455	119	429	510	50	32	750x580x800	42
TIGER 32 inox	1ph 1840/2.5 3ph 2.200/3	1ph/3ph	400	6	414	330	509	470	108	438	562	77	39	750x580x800	49



SPEEDY L 100 - 130

Hamburgatrici caratterizzate da una forma arrotondata semplice e compatta.
Realizzate in lega di alluminio anodizzato.
Contenitore porta cellophane incorporato pronto per l'uso.
Piedini in gomma.

*Simple and compact patty press with rounded design.
Made in anodized aluminium alloy.
Ready to use built-in cellophane sheet container.
Rubber feet.*







SPEEDY L 100

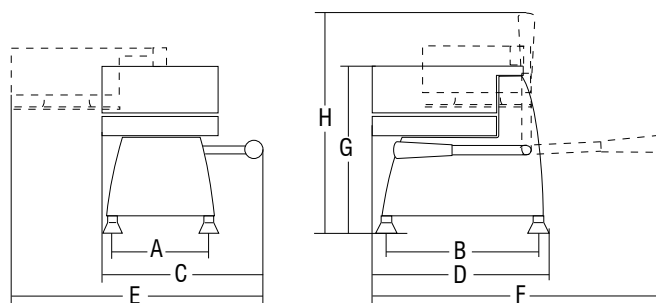

SPEEDY L 130



		A	B	C	D	E	F	G	H			
	mm	mm	mm	mm	mm	mm	mm	mm	mm	kg	mm	kg
SPEEDY L 100	100	140	230	255	270	310	380	260	320	4.5	450x370x350	5.5
SPEEDY L 130	130	140	250	260	310	360	460	275	360	6	450x370x350	7



BS 1840

Macchina dalla linea semplice e robusta, sicura e facile all'uso. Struttura autoportante realizzata in fusione di alluminio anodizzato, brillante, igienico e anticorrosivo. Complete di piano, spingicarne e porzionatrice in acciaio inox AISI 304. Comandi 24V con micro di sicurezza su porta, centralina di controllo ridondante e freno motore (CE). Massima semplicità e precisione nella regolazione sia orizzontale che verticale della puleggia superiore. Massima aderenza della lama alla puleggia grazie alla lavorazione semicurva delle pulegge e ad una perfetta regolazione. Cuscinetti ermetici su puleggia superiore. Pulizia facilitata grazie a 2 particolari accorgimenti di costruzione:

- tutte le parti elettriche sono posizionate sotto al piano di lavoro all'interno di una scatola apposita isolata IP 65.
- Svitando due manopole è possibile asportare lama, puleggia superiore e supporto della puleggia, si presenta così una superficie priva di ingombri.









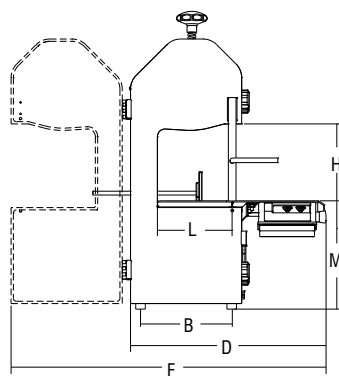
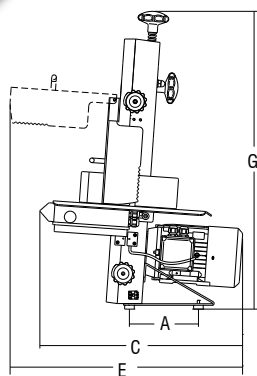







Potenti motori asincroni e ventilati a 4 poli protetti con paraolio di tenuta. Utilizzano lame temperate da 16 mm per taglio di ossa, congelato e fresco.

Simple and sturdy machines that are safe and easy to use. Stand-alone structure made of cast anodized aluminium, shiny, hygienic and rustproof. Features a counter, meat pusher and serving portioner in stainless steel AISI 304. 24V controls with safety micro-switch on door, redundant ECU and motor brake (CE). Maximum simplicity and precision in both horizontal and vertical adjustment of the upper pulley. Maximum blade adhesion to the pulley, thanks to the semi-curved shape of the pulleys and an ideal adjustment. Sealed bearings on upper pulley. Smooth cleaning thanks to 2 special manufacturing details:

- All the electrical parts are located beneath the work surface inside an appropriate IP 65 insulated box.
- By simply unscrewing two knobs, you can remove the blade, upper pulley and its support, thus presenting a surface free of encumbrance.

Powerful 4-pole asynchronous and ventilated motors protected with oil seal. Equipped with 16 mm tempered blades for cutting bones, frozen and fresh foods.



																	
	mm	Hp/r.p.m.	mm	mm	A	B	C	D	E	F	G	H	L	M	kg	mm	kg
BS 1840	1840	1 ^{ph} 15/1.400 3 ^{ph} 2/1.400	250	445x485	180	300	530	600	640	950	915	249	240	305	40	720x570x1200	52



BS inox 1650 - 1840









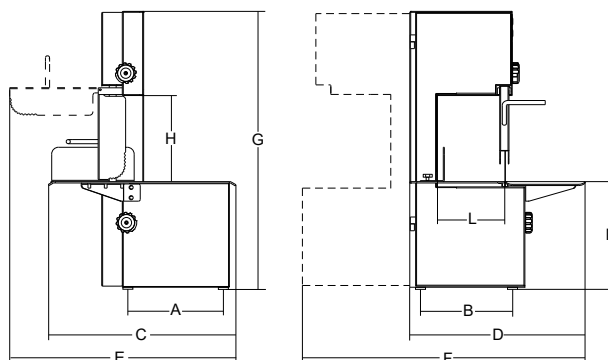







Costruzione in acciaio inox AISI 304.
 Pulegge calibrate costruite in alluminio brillantato.
 Cuscinetti ermetici su puleggia superiore.
 Potenti motori asincroni e ventilati protetti con paraolio di tenuta.
 Comandi 24V con micro di sicurezza su porta e cassetto, centralina di controllo ridondante e freno motore (CE).
 Rapido sblocco puleggia superiore agevola la pulizia e il cambio lama.
 Raschiatori facilmente rimovibili e sostituibili.
 Potenti motori a 6 e 8 poli sviluppano grande forza con poco assorbimento.
 Motori monofase con protezione termica di serie.
 Lavabili con spruzzo d'acqua (no alta pressione).
 Comandi in acciaio inox IP 67.
 Utilizzano lame temperate da 16 mm per taglio di ossa, congelato e fresco.

*AISI 304 stainless steel body.
 Calibrated pulleys made of polished aluminium.
 Sealed bearings on upper pulley.
 Powerful asynchronous and ventilated motors protected by lip seals.
 Controls 24 V with safety micro-switch on door and tray, redundancy control unit and motor brake (CE).
 Upper pulley with quick-release mechanism to facilitate cleaning and blade change.
 Easily removable and replaceable scrapers.
 Powerful 6- and 8-pole motors generate considerable force with limited power input.
 Single-phase motors with standard thermal protection.
 Washable with water jet (not high pressure).
 IP 67 stainless steel controls.
 Equipped with 16 mm tempered blades for cutting bones, frozen and fresh foods.*



BS 1840 inox



																		
	mm	watt/HP.	r.p.m.	mm	mm	mm	mm	mm	mm	mm	mm	mm	mm	mm	kg	mm	kg	
BS 1650 Inox	1650	1ph 1.100/1,5 3ph 1.500/2	1400	210	415x470	315	314	535	520	640	862	815	249	197	320	46	570x720x1020	58
BS 1840 Inox	1840	1ph 1.100/1,5 3ph 1.500/2	1400	250	455x470	315	334	537	560	640	923	843	249	237	320	51	570x720x1020	63



BS inox 2020

Costruzione in acciaio inox AISI 304.
Pulegge calibrate costruite in alluminio brillantato.
Cuscinetti ermetici su puleggia superiore.
Potenti motori asincroni e ventilati protetti con paraolio di tenuta. Comandi 24V con micro di sicurezza su porta e cassetto, centralina di controllo ridondante e freno motore (CE). Rapido sblocco puleggia superiore agevola la pulizia e il cambio lama. Raschiatori facilmente rimovibili e sostituibili. Potenti motori a 6 e 8 poli sviluppano grande forza con poco assorbimento. Motori monofase con protezione termica di serie. Lavabili con spruzzo d'acqua (no alta pressione). Comandi in acciaio inox IP 67. Utilizzano lame temperate da 16 mm per taglio di ossa, congelato e fresco.

*AISI 304 stainless steel body.
Calibrated pulleys made of polished aluminium.
Sealed bearings on upper pulley. Powerful asynchronous and ventilated motors protected by lip seals. Controls 24 V with safety micro-switch on door and tray, redundancy control unit and motor brake (CE). Upper pulley with quick-release mechanism to facilitate cleaning and blade change. Easily removable and replaceable scrapers. Powerful 6- and 8-pole motors generate considerable force with limited power input. Single-phase motors with standard thermal protection. Washable with water jet (not high pressure). IP 67 stainless steel controls. Equipped with 16 mm tempered blades for cutting bones, frozen and fresh foods.*









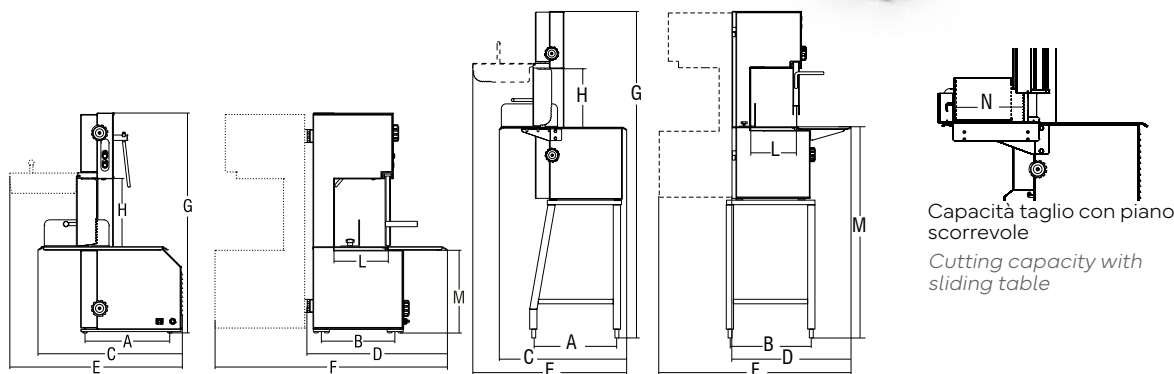









BS 2020 inox



BS 2020 inox FS



Capacità taglio con piano scorrevole
Cutting capacity with sliding table

																			
	mm	watt/HP	r.p.m.	mm	mm	mm	mm	mm	mm	mm	mm	mm	mm	mm	mm	kg	mm	kg	
BS 2020 inox	2020	1ph 1.100/1,5 3ph 1.500/2	1400	250	475x490	253	346	568	560	710	930	1030	290	236	362	207	61	760x640x1020	73
BS 2020 inox FS	2020	1ph 1.100/1,5 3ph 1.500/2	1400	250	475x490	467	411	568	603	710	930	1650	290	236	980	207	70	760x640x1800	82

www.italianslicers.cominfo@rheninghaus.com**SEDE PRODUTTIVA DI PAVIA**
PAVIA PRODUCTION HEADQUARTERSVia dell'Elettronica, 53
27010 Cura Carpignano (PV)
+39 0382 474396**SEDE PRODUTTIVA DI TORINO**
TURIN PRODUCTION HEADQUARTERSVia Ciriè, 8
10099 San Mauro Torinese (TO)
+39 011 2237514**LE NOSTRE ATTIVITÀ ASSOCIATIVE**
OUR ASSOCIATIVE ACTIVITIES**COLLABORAZIONI**
COLLABORATIONS

© 2025 Copyright Rheninghaus

I diritti sulle immagini appartengono a Rheninghaus.
È vietata la riproduzione, anche parziale, di foto e testi.

I dati tecnici e le specifiche sono soggetti a modifiche senza preavviso.

Image rights belong to Rheninghaus.
Reproduction of photos and text, even partial, is prohibited.

Technical data and specifications are subject to change without notice.